

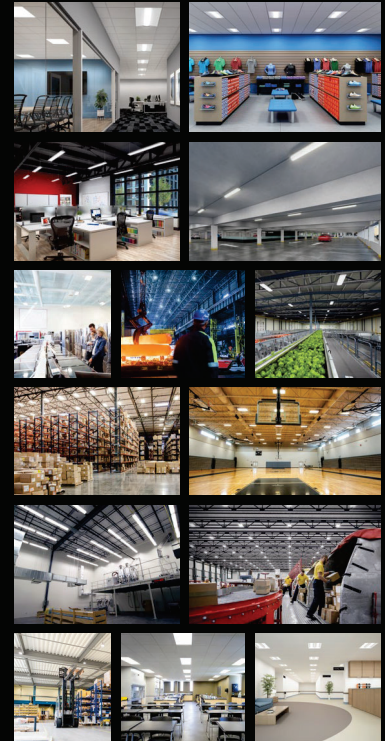

MWS[®]

MODULAR WIRING SYSTEM

Less Time, Less Labor, Lower Costs

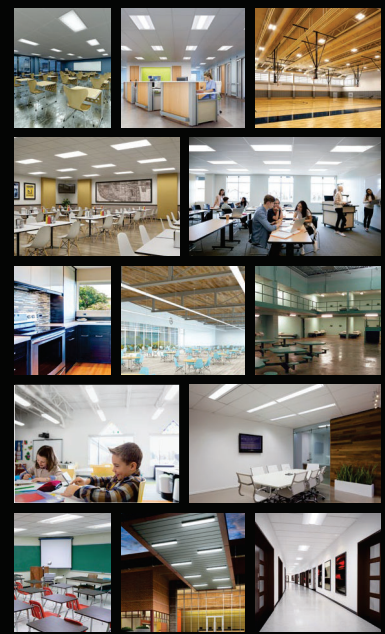

Market Leading System



Lowest total job cost vs. traditional wiring methods

Branch circuit wiring for lighting fixtures and convenience power can be installed in **minutes instead of hours!**

Reduce construction cycle times



Ideal for new construction or renovation



Table of Contents

MWS Overview

3 - 4

MWS Solutions

5 - 6

MWS Components

7 - 8

System Starters

9 - 10

System Extenders and Splitters

11 - 12

Commercial Fixture Interface

13 - 14

System Local Switching

15 - 16

Power Components

17 - 18

Industrial Fixture Interface

19 - 22

Design Guide

23 - 27

Less Time, Less Labor, Lower Costs



Recessed Ceiling

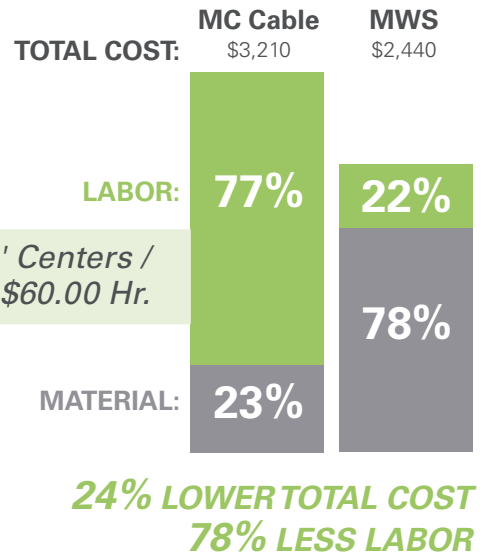

Open Ceiling

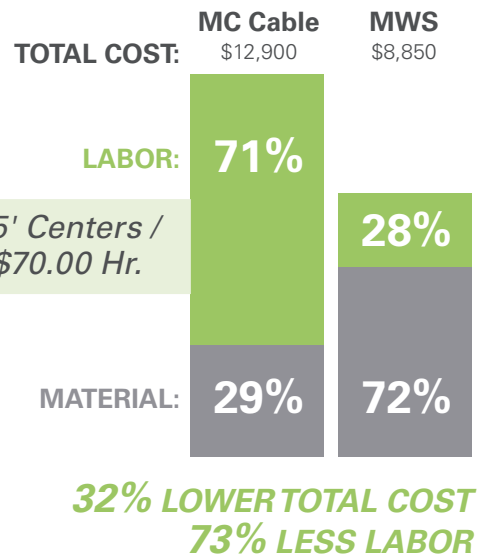

Overview

Cooper Lighting Solution's Modular Wiring System (MWS) is a sustainable wiring solution that solves the challenges of branch circuit wiring in new construction and renovation projects. MWS is simple and cost-effective. Components arrive at the job site completely assembled and ready to be snapped together to form a branch circuit system. No bending, cutting or assembly is needed.

- Reduces installation setup time and labor costs
- Flexible, reconfigurable system enabling future changes within a space
- Allows for make or break under load
- Improved worker safety when servicing fixtures
- MWS is portable and may be considered as "Tangible Personal Property" and eligible for potential tax savings through accelerated depreciation
- Save time with integral 0-10V circuit, power and control in a single jacketed cable

Applications

MWS systems are so versatile that they seamlessly work with recessed, pendant, surface, and downlight LED and LFL luminaires in multiple applications.

- Warehousing
- Commercial office
- Manufacturing
- Raised floor
- Education
- Convenience power
- General ambient
- Retail spaces
- Switchbox, panel or homerun
- Distribution centers

Performance Features

Flexible

- Positive self-grounding locking clip that fits into any 1/2" knockout on a fixture
- MWS fits on any manufacturer's luminaires that has 1/2" or greater knockout or opening

Modular

- External fixture access for safe and easy servicing
- Simple plug and play installation
- Galvanized steel housing exterior with integral key and latch design

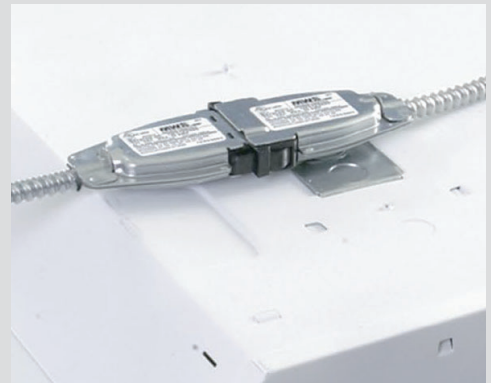
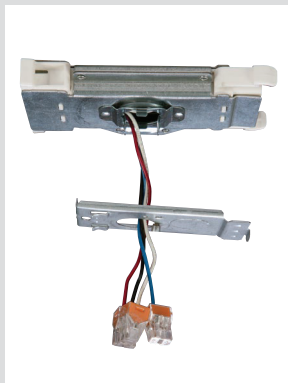

Features and Benefits

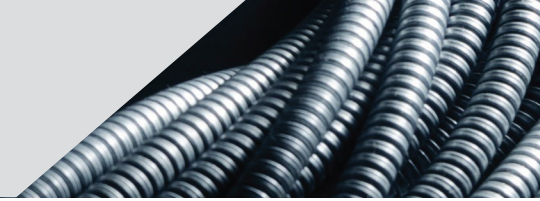

Scalable

- Five wire circuiting capabilities
- Easily add to existing installations
- Available voltages include 120V, 277V, 347V, 208V and 480V circuits
- Available with optional single circuit 16AWG dimming wires for 0-10V control

Secure

- Internal, double-blade contact design
- Fast, positive latching to prevent accidental disconnect
- Designed for make-or-break protection jacketed cable
- Copper conductors are THHN insulated wire rated 90°C

Convenience

- Reusable components make layout changes quick and easy
- Satisfies local codes nationwide
- Pre-stripped 16AWG wire or 18AWG connectors allow for easy termination at fixture
- Integral 0-10V circuit allows power and control to be pulled in a single jacketed cable

Safe

- UL listed under standard 183 and approved in Article 604 of the NEC
- Special key locations for each voltage prevent connection errors during installation
- True dead front design prevents accidental contact with live components
- Meets the NEC and UL listing requirements for combining power/lighting circuits and class 2 or class 3 signal/control circuits in the same cable

Maximize Savings in Time and Dollars

MWS offers the lowest-cost wiring option for commercial and industrial buildings. The plug-in connections provide quick results with less labor and lower total installed costs when compared to traditional pipe and wire methods. Faster installation means faster payback.

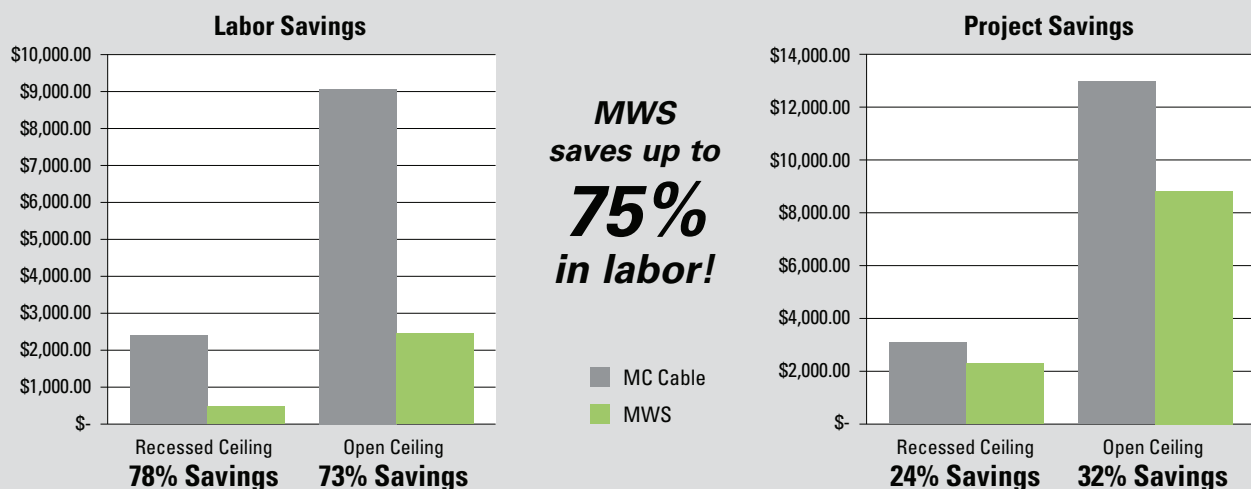

Simple solutions for a complex world

Office • Education • Hospitality • Retail • Industrial • Manufacturing • Sports Venues

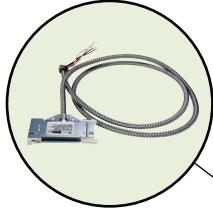

T Cable
TC

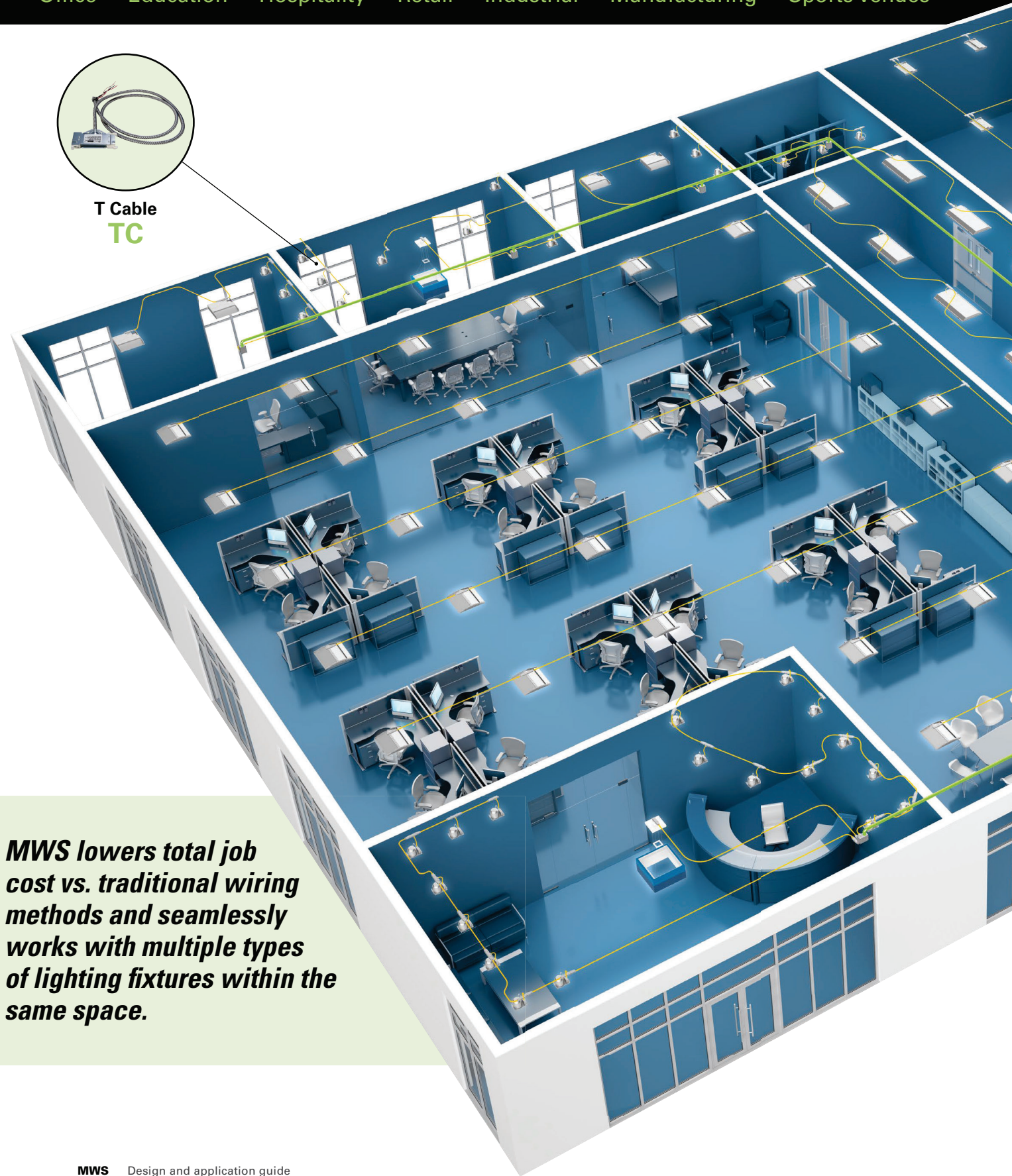

MWS lowers total job cost vs. traditional wiring methods and seamlessly works with multiple types of lighting fixtures within the same space.

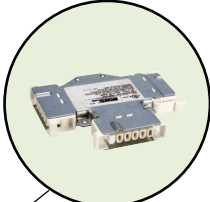
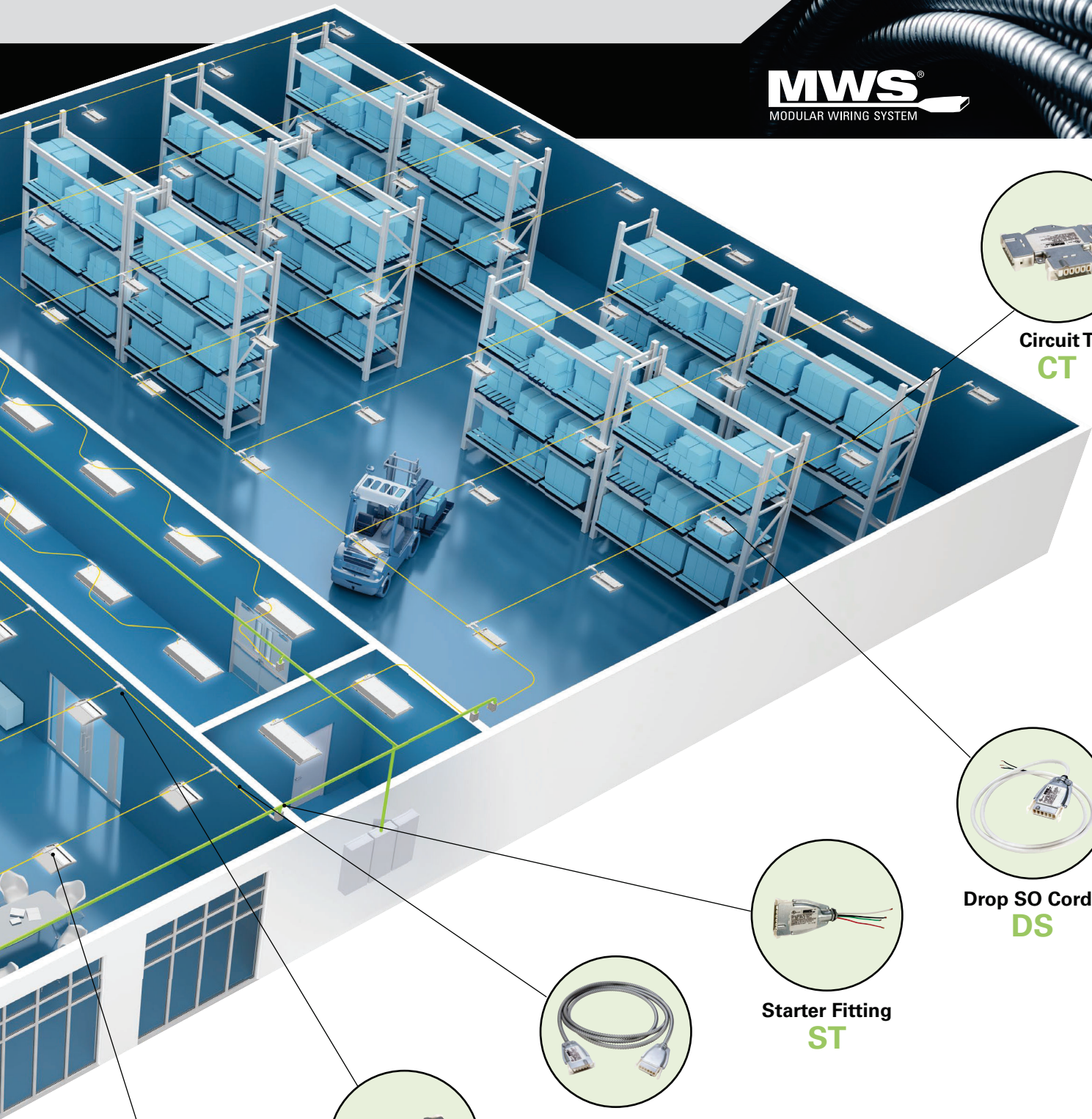

Circuit T
CT

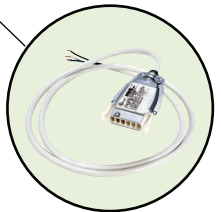

Drop SO Cords
DS

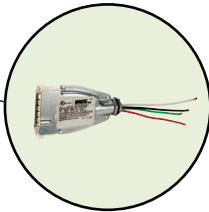

Starter Fitting
ST

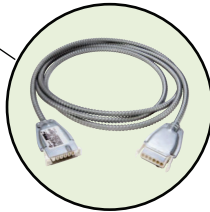

Extender Cable
EC

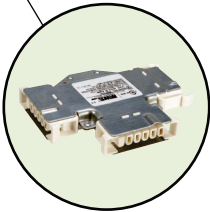

Splitter
SP

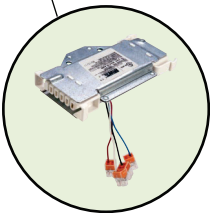

Fixture Fitting
FF

MWS Components

System Starters

Starter Fitting (**ST**) is the starting point for the MWS system. The Fitting is installed in a standard 1/2" knockout of an electrical junction box, duct or panel. Since the Starter Fitting is mounted externally, it does not impact wire fill. MWS Starters are also available as Starter Cables with 9, 15, or 21 feet of MC cable.

The Starter Fixture Cable (**SF**) starts the MWS circuit immediately at the electrical junction box or switch box and continues to the first lighting fixture. Subsequent fixtures connected to the Starter Fixture cable are wired with standard Fixture Cables (**FC**). The line side connector installs into any 1/2" knockout and has 6" #18 leads to connect to the fixture wiring. The installer is responsible for wiring power between switch boxes. **Page 9-10**

Starter Fitting ST



Starter Fixture Cable SF

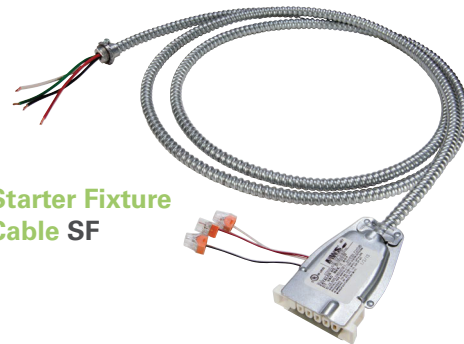

Extenders and Splitters

The Extender Cable (**EC**) continues the MWS circuit between MWS components that interface with lighting fixtures, switches, sensors and convenience power outlets. Any MWS cable component may have length added with an Extender Cable. **Page 11**

The MWS Splitter (**SP**) adds an additional connection at any point within the MWS circuit allowing the circuit to split into two different directions. **Page 12**

Splitter SP

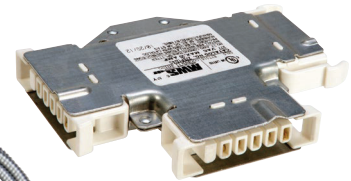

Extender Cable EC



Commercial Fixture Components

The Fixture Cable (**FC**) continues power from the Starter or Switch Drop to the first lighting fixture and between lighting fixtures. The line side connector snaps into any 1/2" knockout and has 6" #18 leads to connect to fixture wiring. MWS Fixture Cables may have length added with an Extender Cable. **Page 13**

The Fixture Fitting (**FF**) feeds power to any lighting fixture while allowing the circuit to feed through to the next fixture. Extender Cables (**EC**) feed power to each fitting. Switch Drops (**SD**) can be connected in front of a Fixture Fitting to introduce local switching. Power Fitting (**PF**) perform the same function but with 12 AWG leads. **Page 14**

Fixture Fitting FF
Power Fitting PF



Fixture Cable FC





Switch Drops

The Switch Drop (**SD**) introduces local switching into the MWS circuit. Switch Drops may be installed during rough-in or renovations. Extender Cables (**EC**) bring power from starters to the first Switch Drop and between consecutive Switch Drops. Switch Drops can also be connected together for multiple switch locations. **Page 15-16**

Switch Drop SD

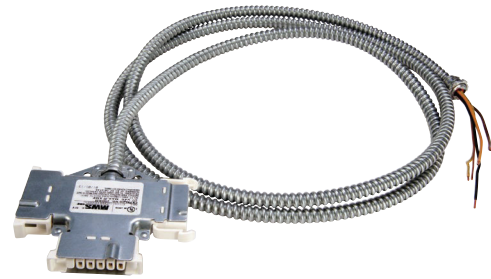

Power

The T Cable (**TC**) feeds power to wall mounted or ceiling mounted fixtures and convenience outlets while feeding circuits downstream to another electrical component. Extender Cables feed power to each T Cable. **Page 17**

The MWS Drop Cable (**DC**) supplies power to out of system units that are wall mounted or ceiling mounted. MWS Drop cables may be plugged into the last fixture cable (**FC**) or from a Splitter (**SP**) anywhere within the system. **Page 18**

T Cable TC

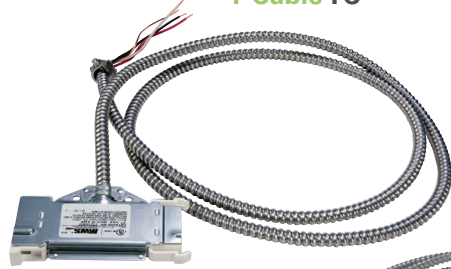

Drop Cable DC

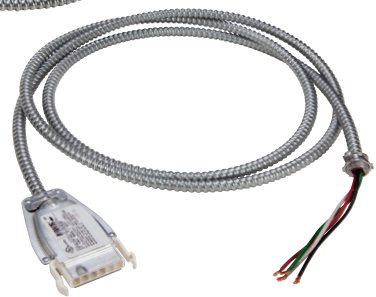

Industrial Fixture Components

The Drop SO Cords (**DS**) are used to feed Industrial HID and Fluorescent lighting fixtures from a CircuitT (**CT**) that provides circuit selection. Fixtures wired with MWS Drop SO Cords can be unplugged under load and relocated without interrupting power to fixtures downstream. **Page 19**

The CircuitT (**CT**) feeds power to Industrial lighting fixtures wired with Drop SO Cords or Drop cables. The CircuitT provides circuit selection at each fixture plug allows fixtures to be disconnected without interrupting power downstream. **Page 20**

The T SO Cord (**TS**) are used to feed Industrial lighting fixtures while allowing the circuit to feed through to the next fixture. **Page 21-22**

Drop SO Cords DS



CircuitT CT

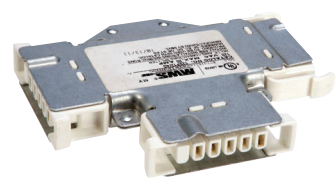

T SO Cords TS

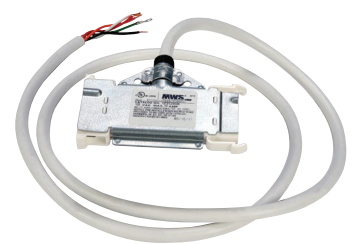

System Starters

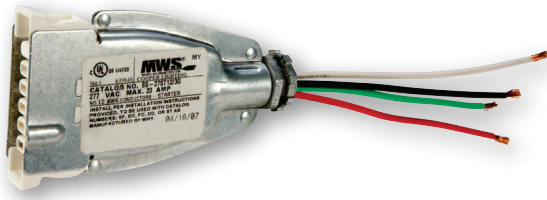

Starter Fitting ST

The MWS Starter Fitting is the starting point for the MWS system. The Fitting is installed in a standard 1/2" knockout of an electrical junction box, duct or panel. Since the Starter Fitting is mounted externally it does not impact wire fill.

- Starter Fittings come with threaded locknut connector and 6" leads pre-stripped for easy termination.
- Starter Cables include a cast threaded locknut fitting at the end of the specified length of cable with 6" leads pre-stripped for easy termination.

All unused outlets require a MWS dust cover. MWS ST, SP, SD, CT and TC are shipped with one dust cover attached.

120V / 277V / 347V 12/2G - 12/3G - 12/4G - 10/2G - 10/3G - 10/4G

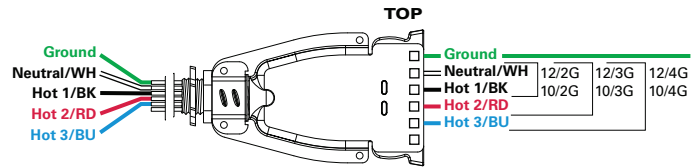

120V / 277V / 347V - 2 CIRCUIT, 2 NEUTRAL 12/4G 2N - 10/4G 2N

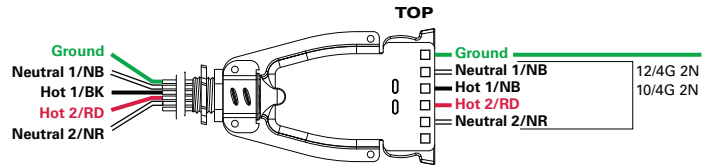

208V / 240V / 480V 12/2G - 12/3G - 12/4G - 10/2G - 10/3G - 10/4G

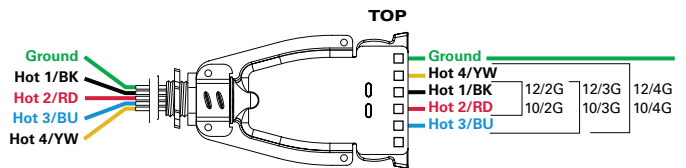

NOTE: Starter Fitting with 1/2" threaded stud shown.

Flex cable with integral 0-10V dimming cable

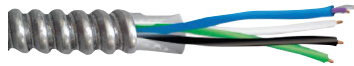

System View - MWS Starter Fitting

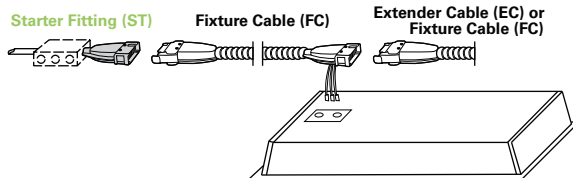

MWS Starter Cable

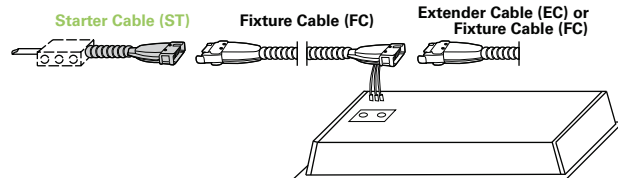

Order Information

SAMPLE ORDER NUMBER: **27ST12/2G**

Voltage	Component	Conductors and Size	Cable Length (Feet)	Options
12=120V 20=208V 24=240V 27=277V 34=347V 48=480V	ST=Starter	10/2G=#10, 2 Conductors Plus Ground 10/3G=#10, 3 Conductors Plus Ground 10/4G=#10, 4 Conductors Plus Ground 12/2G=#12, 2 Conductors Plus Ground 12/3G=#12, 3 Conductors Plus Ground 12/4G=#12, 4 Conductors Plus Ground	09=9' 15=15' 21=21' [Blank]=No Cable	2N=2 Neutral ⁽¹⁾ Notes (1) 12/4G and 10/4G only.

Order Information (0-10V)

SAMPLE ORDER NUMBER: **27ST12/2G-010V**

Voltage	Component	Conductors and Size	Cable Length (Feet)	Dimming
12=120V 27=277V 34=347V	ST=Starter	10/2G=#10, 2 Conductors Plus Ground 12/2G=#12, 2 Conductors Plus Ground	09=9' 15=15' 21=21' [Blank]=No Cable	010V=0-10V Dimming

Shipping Data

Standard Cable Lengths	Unit Wt.	Standard Qty./Carton
0'	.7 lbs.	60
9'	3.0 lbs.	9
15'	4.5 lbs.	6
21'	6.3 lbs.	4

System Starters

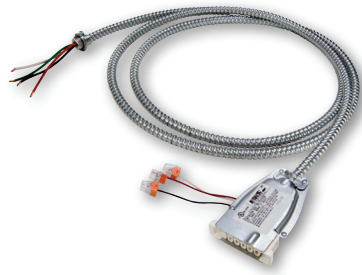

Starter Fixture Cable SF

The MWS Starter Fixture Cable (SF) starts the MWS circuit immediately at the electrical junction box or switch box and continues to the first lighting fixture. Subsequent fixtures connected to the Starter Fixture Cable are wired with standard Fixture Cables (FC).

The line side connector installs into any 1/2" knockout and has 6" leads to connect to the fixture or access plate.

- Positive fixture locking clip locks into any 1/2" knockout and is self grounding to the fixture or access plate.
- Tap leads to the fixture come standard with poke home connectors for fast termination to fixture leads.
- The whip end of the Starter Fixture Cable is supplied with a 1/2" MC cable fitting and 6" #18 leads pre-stripped for easy termination to building wiring.

All unused outlets require a MWS dust cover. MWS ST, SP, SD, CT and TC are shipped with one dust cover attached.

Flex cable with integral 0-10V dimming cable



120V / 277V / 347V

12/2G - 12/3G - 12/4G

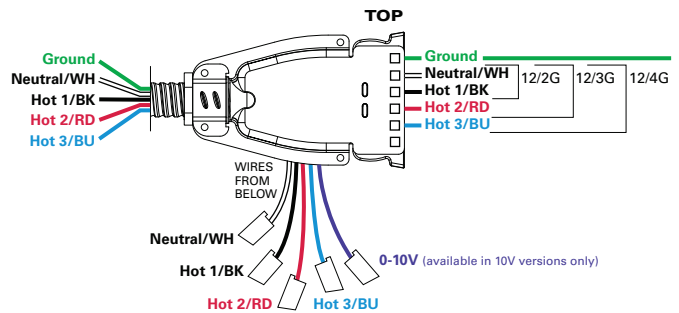

120V / 277V / 347V - 2 CIRCUIT, 2 NEUTRAL

12/4G 2N ONLY

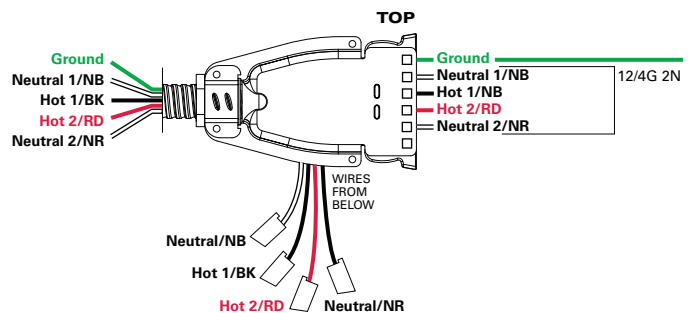

NOTE: Ground wire to fixture included with GW option.

System View - MWS Starter Fixture Cable

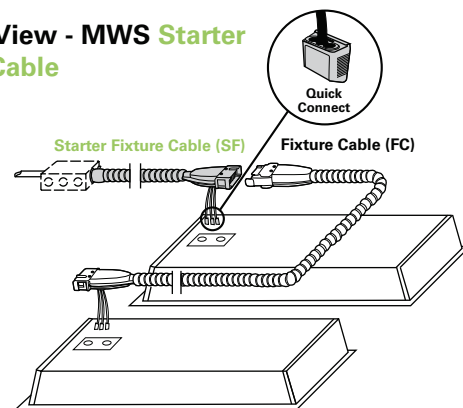

Order Information

SAMPLE ORDER NUMBER: **27SF12/2G09**

Voltage	Component	Conductors and Size	Cable Length (Feet)	Options
12=120V 27=277V 34=347V	ST=Starter Fixture Cable	12/2G=#12, 2 Conductors Plus Ground 12/3G=#12, 3 Conductors Plus Ground 12/4G=#12, 4 Conductors Plus Ground	09=9' 15=15' 21=21'	2N=2 Neutral ⁽¹⁾ Notes (1) 12/4G only.

Order Information (0-10V)

SAMPLE ORDER NUMBER: **27SF12/2G09-010V**

Voltage	Component	Conductors and Size	Cable Length (Feet)	Dimming
12=120V 27=277V 34=347V	ST=Starter Fixture Cable	12/2G=#12, 2 Conductors Plus Ground	09=9' 15=15' 21=21'	010V=0-10V Dimming

Shipping Data

Standard Cable Lengths	Unit Wt.	Standard Qty./ Carton
9'	3.0 lbs.	9
15'	4.5 lbs.	6
21'	6.3 lbs.	4

System Extenders and Splitters



Extender Cable EC

The MWS Extender Cable (EC) continues the MWS circuit between MWS components that interface with lighting fixtures, switches and convenience power outlets.

Any MWS cable component may have length added with an Extender Cable.

All unused outlets require a MWS dust cover. MWS ST, SP, SD, CT and TC are shipped with one dust cover attached.

120V / 277V / 347V

12/2G - 12/3G - 12/4G - 10/2G - 10/3G - 10/4G

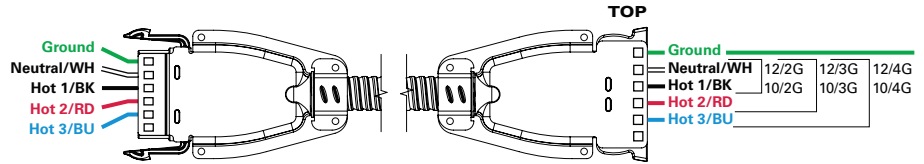

120V / 277V / 347V - 2 CIRCUIT, 2 NEUTRAL

12/4G 2N - 10/4G 2N

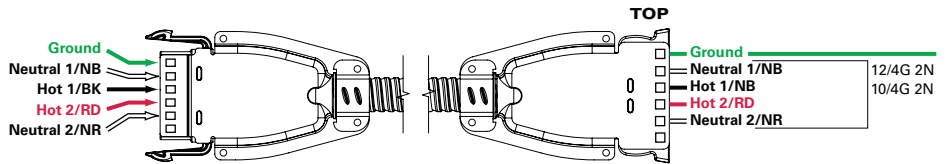

208V / 240V / 480V

12/2G - 12/3G - 12/4G - 10/2G - 10/3G - 10/4G

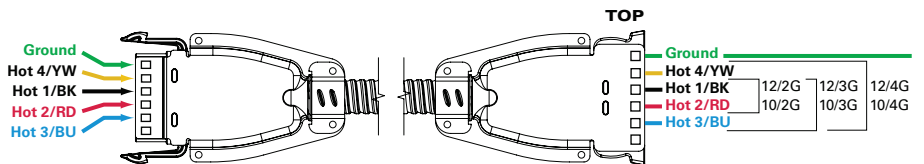

Flex cable with integral 0-10V dimming cable



System View - MWS Extender Cables

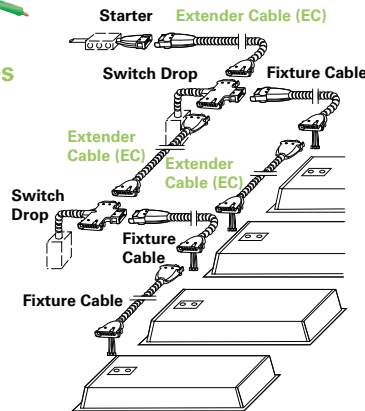
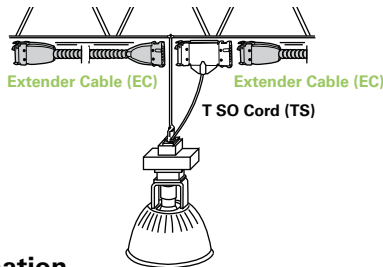

Order Information

SAMPLE ORDER NUMBER: **27EC12/3G17**

Voltage	Component	Conductors and Size	Cable Length (Feet)	Options
12=120V 20=208V 24=240V 27=277V 34=347V 48=480V	EC=Extender Cable	10/2G=#10, 2 Conductors Plus Ground 10/3G=#10, 3 Conductors Plus Ground 10/4G=#10, 4 Conductors Plus Ground (2) 12/2G=#12, 2 Conductors Plus Ground 12/3G=#12, 3 Conductors Plus Ground 12/4G=#12, 4 Conductors Plus Ground (2)	05=5' 07=7' 09=9' 11=11' 13=13' 15=15' 17=17'	19=19' 21=21' 26=26' 31=31' 36=36' 41=41'
Notes (2) Compatible with 5LT components.			Notes (1) 12/4G and 10/4G only.	

Order Information (0-10V)

SAMPLE ORDER NUMBER: **27EC12/3G17-010V**

Voltage	Component	Conductors and Size	Cable Length (Feet)	Dimming
12=120V 27=277V 34=347V	EC=Extender Cable	10/2G=#10, 2 Conductors Plus Ground 12/2G=#12, 2 Conductors Plus Ground	07=7' 11=11' 17=17' 21=21'	26=26' 31=31' 36=36' 41=41'
				010V=0-10V Dimming

Shipping Data

Standard Cable Lengths	Unit Wt.	Standard Qty./ Carton
5'	2.0 lbs.	12
7'	2.5 lbs.	10
9'	3.0 lbs.	9
11'	3.5 lbs.	8
13'	4.0 lbs.	7
15'	4.5 lbs.	6
17'	5.0 lbs.	6
19'	5.6 lbs.	5
21'	6.3 lbs.	5
26'	7.8 lbs.	4
31'	9.3 lbs.	4
36'	10.3 lbs.	4
41'	12.3 lbs.	4

System Extenders and Splitters

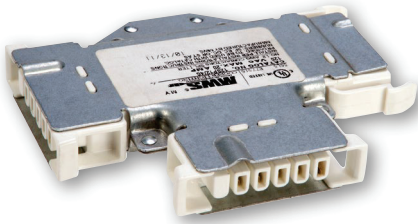

Splitter SP

The MWS Splitter (SP) adds an additional connection at any point within the MWS circuit allowing the circuit to split into two different directions.

All unused outlets require a MWS dust cover. MWS ST, SP, SD, CT and TC are shipped with one dust cover attached.

System View - MWS Splitter

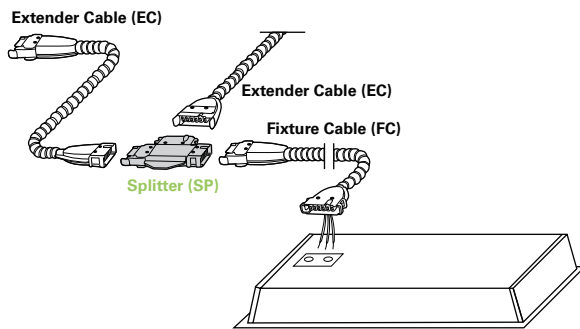

120V / 277V / 347V

12/4G - 12/4GIG - 10/4G

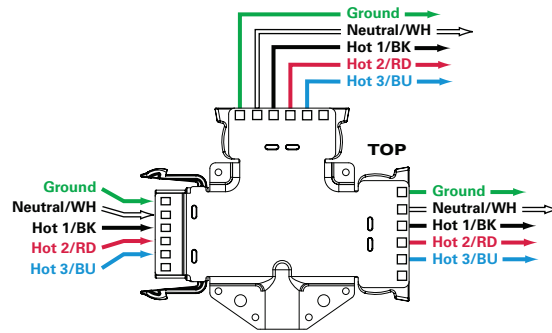

120V / 277V / 347V - 2 CIRCUIT, 2 NEUTRAL

12/4G 2N - 10/4G 2N

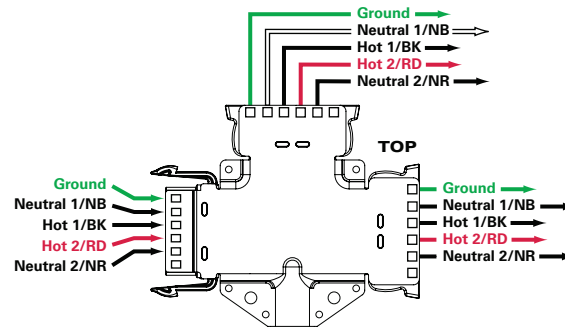

208V / 240V / 480V

12/4G - 10/4G

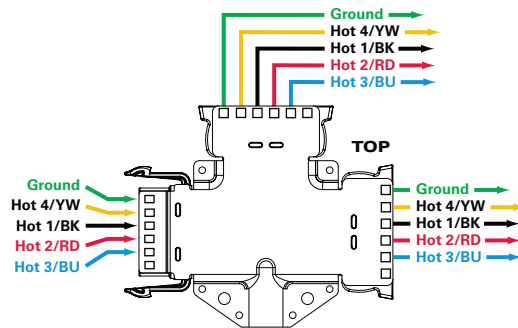

Order Information

SAMPLE ORDER NUMBER: 48SP12/4G

Voltage	Component	Conductors and Size	Options
12=120V 20=208V 24=240V 27=277V 34=347V 48=480V	SP=Splitter	12/4G=#12, 4 Conductors Plus Ground ⁽¹⁾ Notes (1) Compatible with 5LT components.	2N=2 Neutral

Shipping Data

Unit Wt.	Standard Qty./Carton
1.0 lbs.	24

Commercial Fixture Interface

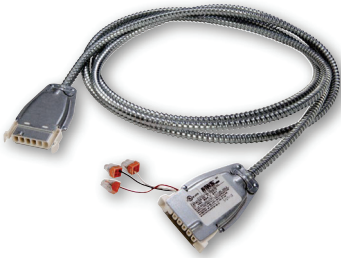

Fixture Cable FC

The MWS Fixture Cable (FC) continues power from the Starter or Switch Drop to the first lighting fixture and between lighting fixtures.

The line side connector snaps into any 1/2" knockout and has 6" #18 leads to connect to fixture wiring.

MWS Fixture Cables may have length added with an Extender Cable.

- Positive fixture locking clip locks into any 1/2" knockout and is self grounding to the fixture or access plate.
- Tap leads to the fixture come standard with poke home connectors for fast termination to fixture leads.

All unused outlets require a MWS dust cover. MWS ST, SP, SD, CT and TC are shipped with one dust cover attached.

120V / 277V / 347V

12/2G - 12/3G - 12/4G

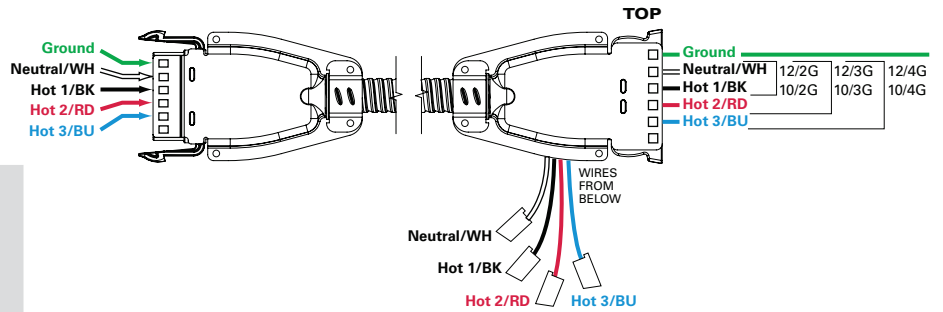

120V / 277V / 347V - 2 CIRCUIT, 2 NEUTRAL

12/4G 2N

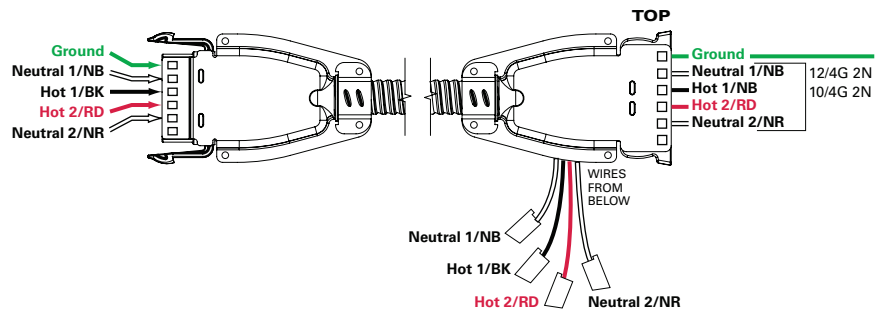

NOTE: Ground wire to fixture included with GW option.

Flex cable with integral 0-10V dimming cable



System View - MWS Fixture Cables

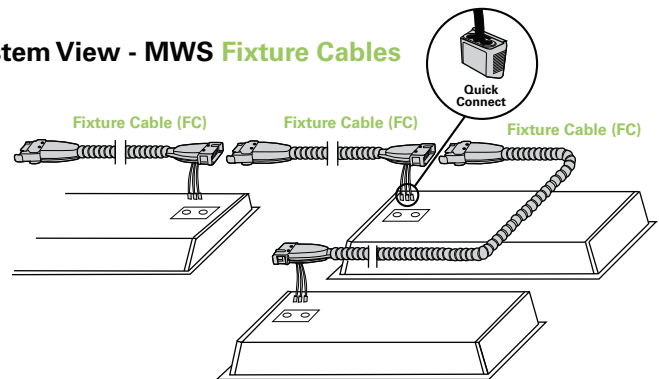

Order Information

SAMPLE ORDER NUMBER: **27FC12/3G11**

Voltage	Component	Conductors and Size	Cable Length (Feet)	Options
12=120V 27=277V 34=347V	FC=Fixture Cable	12/2G=#12, 2 Conductors Plus Ground 12/3G=#12, 3 Conductors Plus Ground 12/4G=#12, 4 Conductors Plus Ground	07=7' 09=9' 11=11' 13=13' 15=15' 17=17'	2N=2 Neutral ⁽¹⁾ Notes (1) Includes redundant grounding for overall armor.

Order Information (0-10V)

SAMPLE ORDER NUMBER: **27FC12/3G11-010V**

Voltage	Component	Conductors and Size	Cable Length (Feet)	Dimming
12=120V 27=277V 34=347V	FC=Fixture Cable	12/2G=#12, 2 Conductors Plus Ground	07=7' 09=9' 11=11' 13=13' 15=15' 17=17'	010V=0-10V Dimming

Shipping Data

Standard Cable Lengths	Unit Wt.	Standard Qty./ Carton
7'	2.5 lbs.	10
9'	3.0 lbs.	9
11'	3.5 lbs.	7
13'	4.0 lbs.	6
15'	4.5 lbs.	6
17'	5.0 lbs.	5

Commercial Fixture Interface

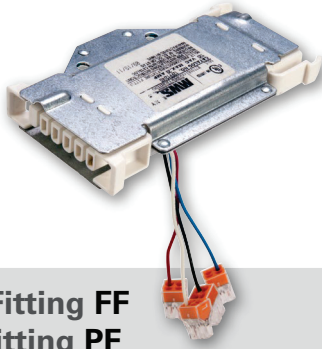

Fixture Fitting FF Power Fitting PF

The MWS Fixture Fitting (FF) feeds power to any lighting fixture while allowing the circuit to feed through to the next fixture.

MWS Switch Drops can be connected in front of a Fixture Fitting to introduce local switching.

MWS Power Fitting (PF) perform the same function but with 12 AWG leads.

- Fixture Fittings and Power Fittings add less than an inch to the height to the fixture or electrical component.
- Positive fixture locking clip locks into any 1/2" knockout and is self grounding to the fixture or access plate.
- FF leads are 6" 18 AWG with poke home connectors. PF have 6" 12 AWG leads prestripped for easy termination.

Flex cable with integral 0-10V dimming cable



System View - MWS Fixture Fitting

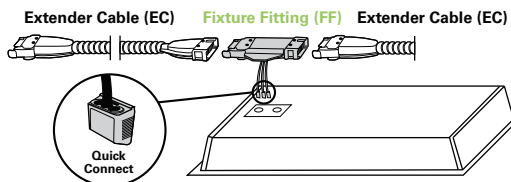

Order Information

SAMPLE ORDER NUMBER: **27FF12/2G**

Voltage	Component	Conductors and Size	Options
12=120V 20=208V 24=240V 27=277V 34=347V 48=480V	FF=Fixture Fitting PF=Power Fitting	10/2G=#10, 2 Conductors Plus Ground 10/3G=#10, 3 Conductors Plus Ground 10/4G=#10, 4 Conductors Plus Ground 12/2G=#12, 2 Conductors Plus Ground 12/3G=#12, 3 Conductors Plus Ground 12/4G=#12, 4 Conductors Plus Ground	2N=2 Neutral ⁽¹⁾ Notes (1) 12/4G and 10/4G only.

Order Information (0-10V)

SAMPLE ORDER NUMBER: **27FF12/2G-010V**

Voltage	Component	Conductors and Size	Dimming
12=120V 27=277V 34=347V	FF=Fixture Fitting	10/2G=#10, 2 Conductors Plus Ground 12/2G=#12, 2 Conductors Plus Ground	010V=0-10V Dimming

120V / 277V / 347V

12/2G - 12/3G - 12/4G - 10/2G - 10/3G - 10/4G

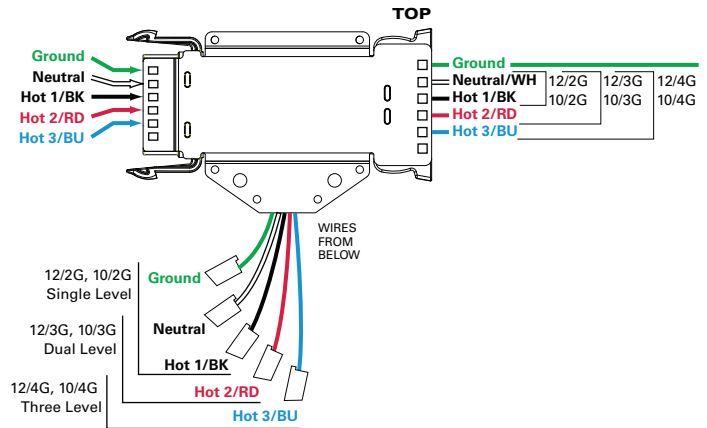

120V / 277V / 347V - 2 CIRCUIT, 2 NEUTRAL

12/4G 2N - 10/4G 2N

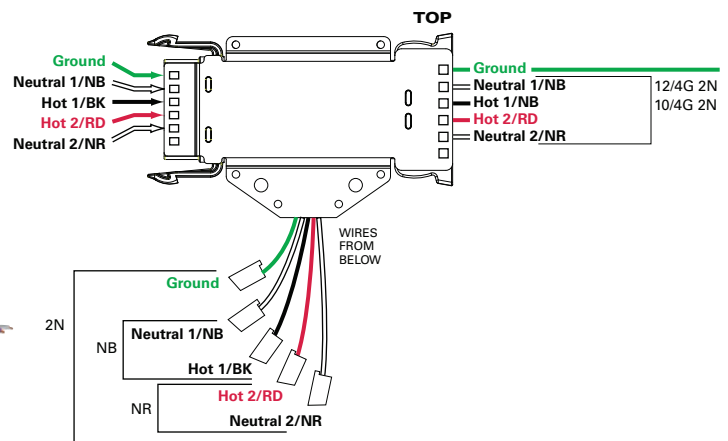

208V / 240V / 480V

12/2G - 12/3G - 12/4G - 10/2G - 10/3G - 10/4G

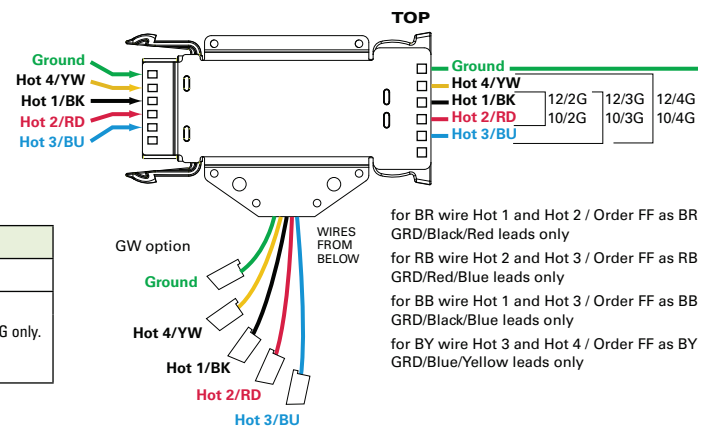

for BR wire Hot 1 and Hot 2 / Order FF as BR GRD/Black/Red leads only
for RB wire Hot 2 and Hot 3 / Order FF as RB GRD/Red/Blue leads only
for BB wire Hot 1 and Hot 3 / Order FF as BB GRD/Black/Blue leads only
for BY wire Hot 3 and Hot 4 / Order FF as BY GRD/Blue/Yellow leads only

Shipping Data

Unit Wt.	Standard Qty./ Carton
1.0 lbs.	32

System Local Switching



Switch Drop SD

The MWS Switch Drop (SD) introduces local switching into the MWS circuit. Switch Drops may be installed during rough-in or renovations.

MWS Extender Cables bring power from starters to the first Switch Drop and between consecutive Switch Drops. Switch Drops can also be connected together for multiple switches at one location.

All unused outlets require a MWS dust cover. MWS ST, SP, SD, CT and TC are shipped with one dust cover attached.

System View - MWS Switch Drop

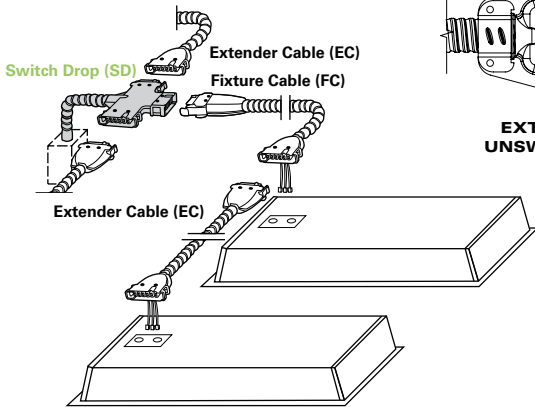

SINGLE CIRCUIT SINGLE LEVEL SWITCHING - SL

#12 ONLY

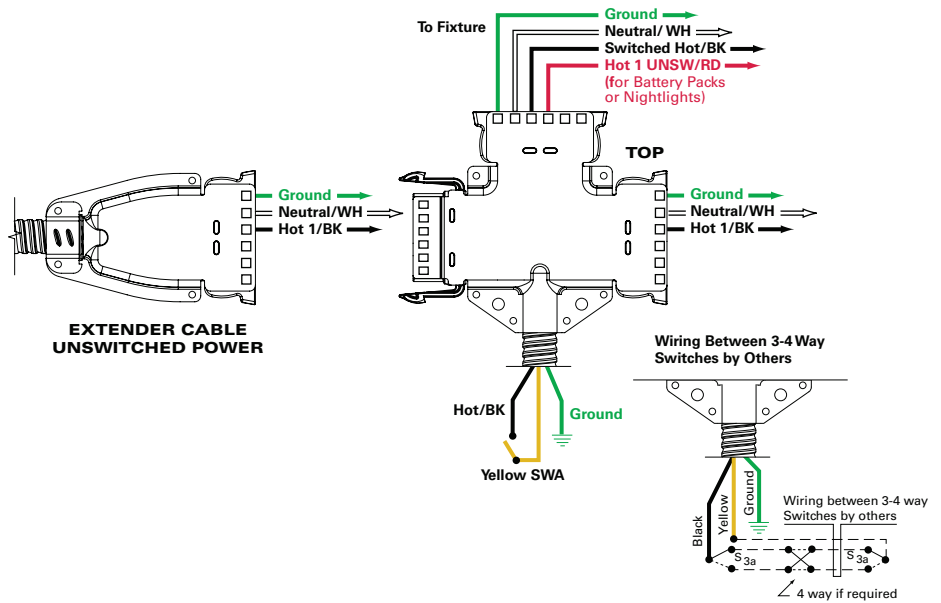

SINGLE CIRCUIT DUAL LEVEL SWITCHING - DL

#12 ONLY

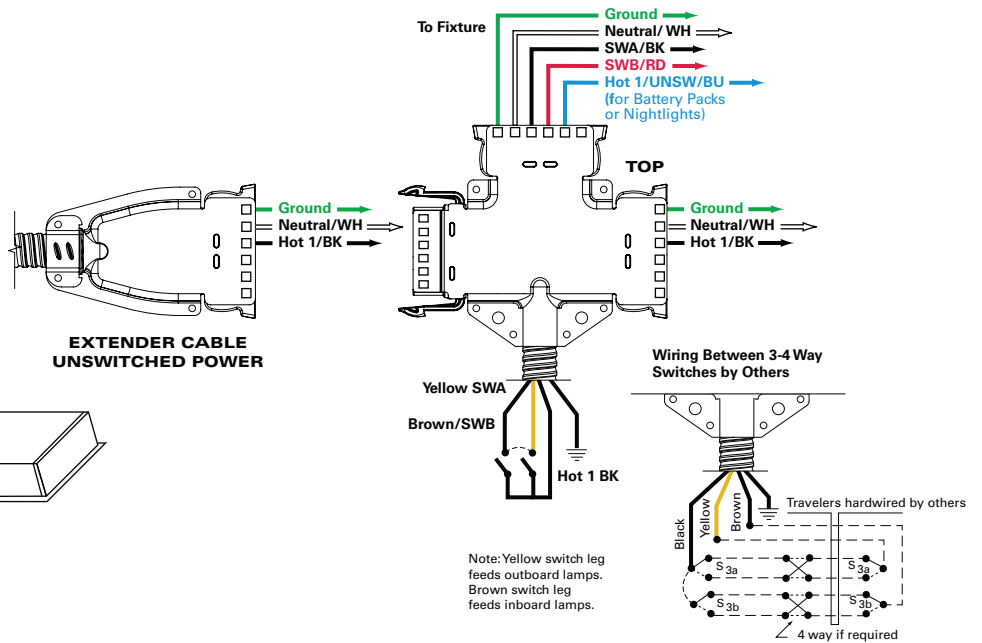

Order Information

SAMPLE ORDER NUMBER: **27SDSL09**

Voltage	Component	Switching Function	Cable Length (Feet)	Options
12=120V 27=277V 34=347V	SD=Switch Drop (1)	3L=Single Circuit, Three Level DC=Dual Circuit, Dual Level DL=Single Circuit, Dual Level SL=Single Circuit, Single Level	01=9' 09=9' 15=15'	N=Neutral Dropped to Switches
	Notes (1) Available in #12-AWG only, rated at 20 amperes.			

Shipping Data

Standard Cable Lengths	Unit Wt.	Standard Qty./Carton
1'	1.8 lbs.	15
9'	3.6 lbs.	10
15'	5.0 lbs.	6

System Local Switching

DUAL CIRCUIT DUAL LEVEL SWITCHING - DC OR 2 CIRCUIT 2 NEUTRAL DUAL LEVEL SWITCHED

#12 ONLY

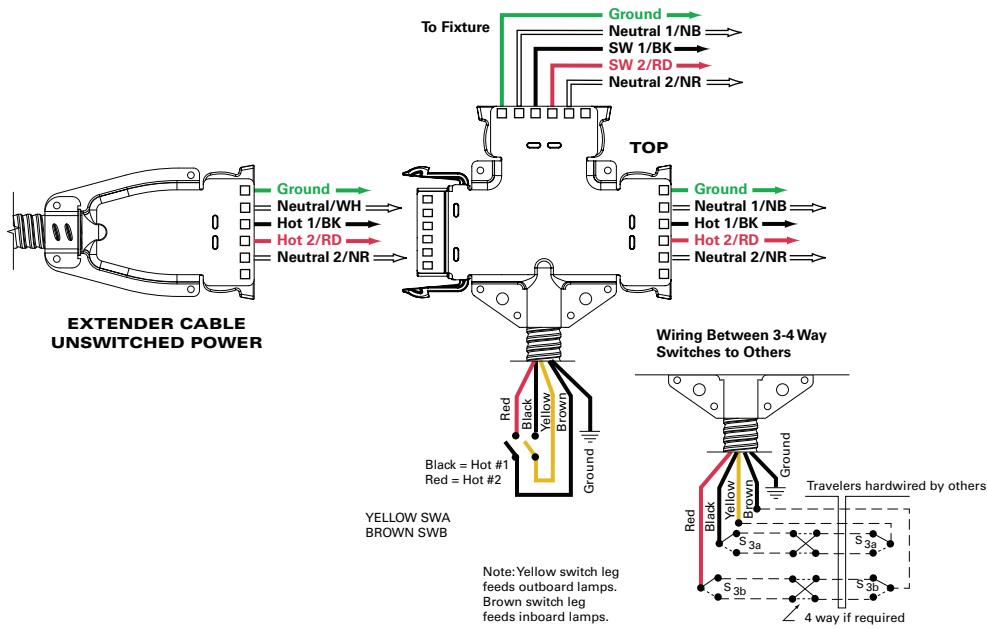

SINGLE CIRCUIT THREE LEVEL SWITCHING - 3L

#12 ONLY

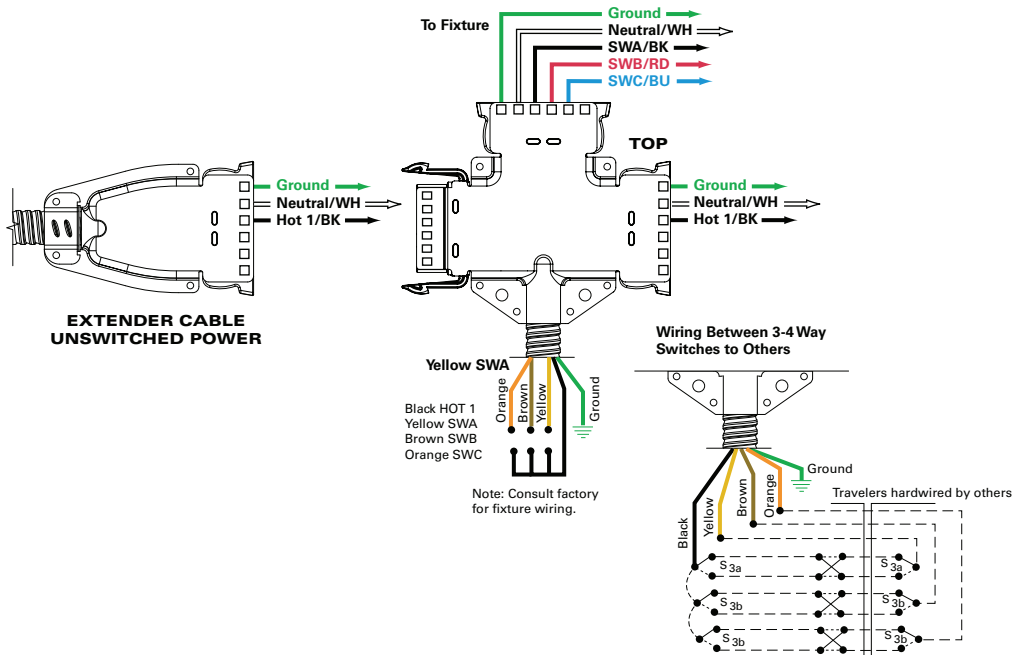

Power Components

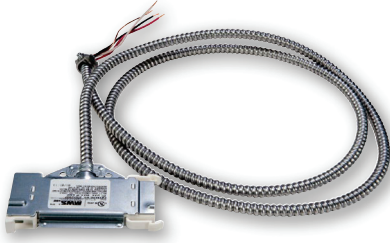

T Cable TC

The MWST Cable (TC) feeds power to wall mounted or ceiling mounted fixtures and convenience outlets while feeding circuits downstream to another electrical component.

- Whip end of cable drop includes a 1/2" MC fitting for connection to a standard 1/2" knockout.
- 6" leads are pre-stripped for easy termination to the device or unit.

All unused outlets require a MWS dust cover. MWS ST, SP, SD, CT and TC are shipped with one dust cover attached.

120V / 277V / 347V

12/2G - 12/3G - 12/4G - 10/2G - 10/3G - 10/4G

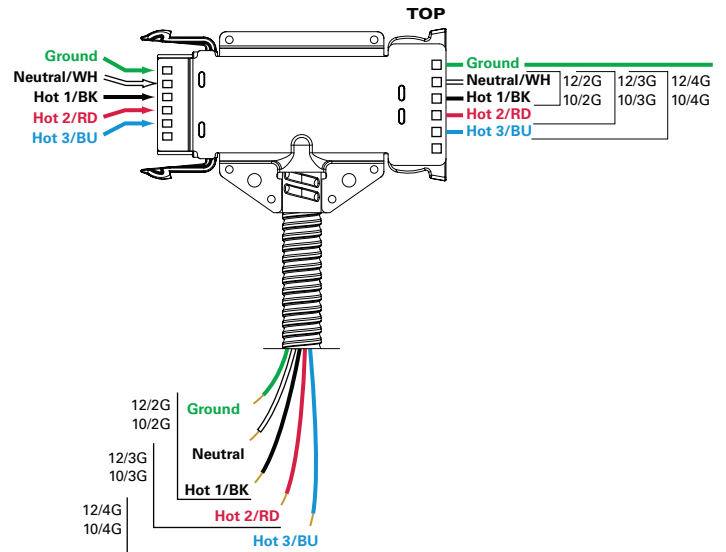

120V / 277V / 347V - 2 CIRCUIT, 2 NEUTRAL

12/4G 2N - 10/4G 2N

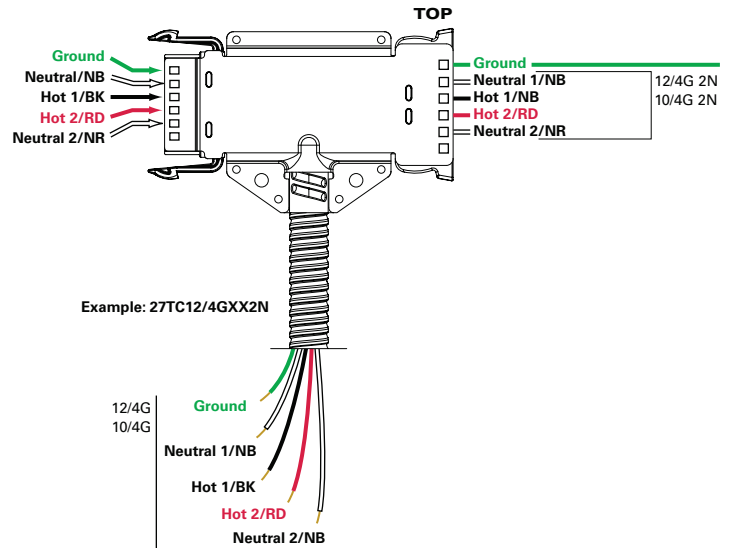

Flex cable with integral 0-10V dimming cable



System View - MWS T Cable

Extender Cable (EC) T Cable (TC) Extender Cable (EC)

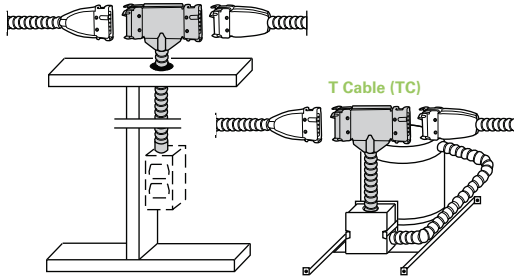

Order Information

SAMPLE ORDER NUMBER: **27TC12/4G11**

Voltage	Component	Conductors and Size	Cable Length (Feet)	Options
12=120V 20=208V 24=240V 27=277V 34=347V 48=480V	TC=T Cable	10/2G=#10, 2 Conductors Plus Ground 10/3G=#10, 3 Conductors Plus Ground 10/4G=#10, 4 Conductors Plus Ground 12/2G=#12, 2 Conductors Plus Ground 12/3G=#12, 3 Conductors Plus Ground 12/4G=#12, 4 Conductors Plus Ground	1=1' 07=7' 09=9' 11=11'	2N=2 Neutral ⁽¹⁾ Notes (1) 12/4G and 10/4G only.

Order Information (0-10V)

SAMPLE ORDER NUMBER: **27TC12/4G11-010V**

Voltage	Component	Conductors and Size	Cable Length (Feet)	Dimming
12=120V 27=277V 34=347V	TC=T Cable	10/2G=#10, 2 Conductors Plus Ground 12/2G=#12, 2 Conductors Plus Ground	1=1' 07=7' 09=9' 11=11'	010V=0-10V Dimming

Shipping Data

Standard Cable Lengths	Unit Wt.	Standard Qty./Carton
1'	1.0 lbs.	12
7'	2.5 lbs.	10
9'	3.5 lbs.	8
11'	4.0 lbs.	7

Power Components



Drop Cable DC

The MWS Drop Cable (DC) supplies power to out of system units that are wall mounted or ceiling mounted.

MWS Drop cables may be plugged into the last fixture cable (FC) or from a Splitter (SP) anywhere within the system.

- Whip end of cable drop includes a 1/2" MC fitting for connection to standard 1/2" knockout.
- 6" leads are pre-stripped for easy termination to the switch. Leads are solid 12 AWG or 10 AWG as specified.

All unused outlets require a MWS dust cover. MWS ST, SP, SD, CT and TC are shipped with one dust cover attached.

120V / 277V / 347V

12/2G - 12/3G - 12/4G

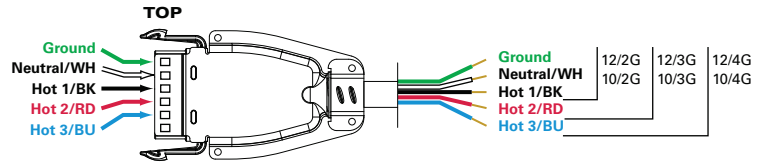

120V / 277V / 347V - 2 CIRCUIT, 2 NEUTRAL

12/4G 2N - 10/4G 2N

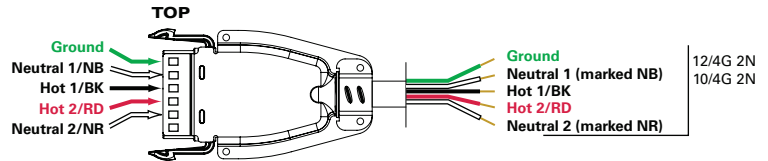

208V / 240V / 480V

12/2G - 12/3G - 12/4G - 10/2G - 10/3G - 10/4G

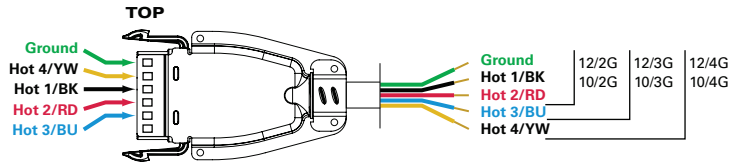

Flex cable with integral 0-10V dimming cable



System View - MWS Drop Cable

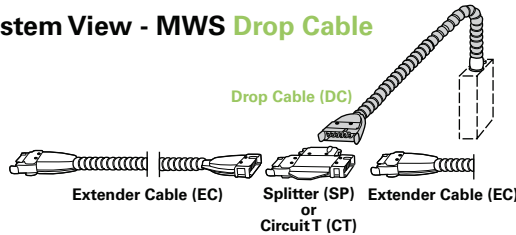

Order Information

SAMPLE ORDER NUMBER: **27DC12/2G11**

Voltage	Component	Conductors and Size	Cable Length (Feet)	Options
12=120V 20=208V 24=240V 27=277V 34=347V 48=480V	DC=Drop Cable	10/2G=#10, 2 Conductors Plus Ground 10/3G=#10, 3 Conductors Plus Ground 10/4G=#10, 4 Conductors Plus Ground 12/2G=#12, 2 Conductors Plus Ground 12/3G=#12, 3 Conductors Plus Ground 12/4G=#12, 4 Conductors Plus Ground	05=5' 09=9' 11=11' 15=15'	2N=2 Neutral ⁽¹⁾ Notes (1) 12/4G and 10/4G only.

Order Information (0-10V)

SAMPLE ORDER NUMBER: **27DC12/2G11-010V**

Voltage	Component	Conductors and Size	Cable Length (Feet)	Dimming
12=120V 27=277V 34=347V	DC=Drop Cable	10/2G=#10, 2 Conductors Plus Ground 12/2G=#12, 2 Conductors Plus Ground	05=5' 09=9' 11=11' 15=15'	010V=0-10V Dimming

Shipping Data

Standard Cable Lengths	Unit Wt.	Standard Qty./ Carton
5'	2.0 lbs.	12
9'	3.0 lbs.	9
11'	3.5 lbs.	8

Industrial Fixture Interface



Drop SO Cord DS

The MWS Drop SO Cords (DS) are used to feed Industrial HID and Fluorescent lighting fixtures from a Circuit T (CT) that provides circuit selection.

Fixtures wired with MWS Drop SO Cords can be unplugged under load and relocated without interrupting power to fixtures downstream.

- 16 AWG SO Cord is pre-stripped for easy termination at the fixture.

All unused outlets require a MWS dust cover. MWS ST, SP, SD, CT and TC are shipped with one dust cover attached.

System View - MWS Drop SO Cord

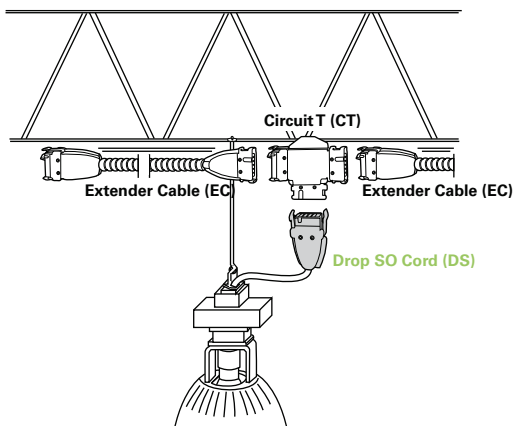

120V / 277V / 347V

16/2G - 16/3G - 16/4G

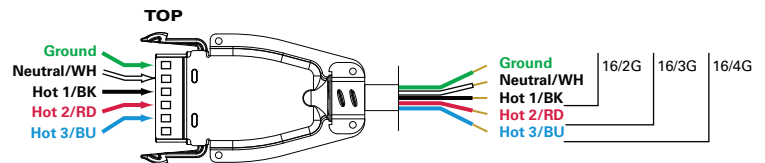

120V / 277V / 347V - 2 CIRCUIT, 2 NEUTRAL

16/4G 2N

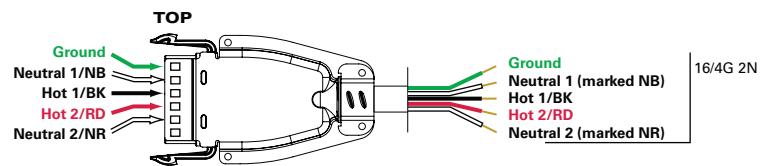

208V / 240V / 480V

16/2G - 16/3G - 16/4G

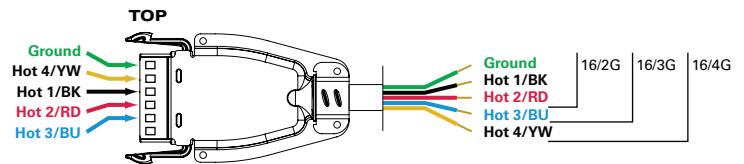

Order Information

SAMPLE ORDER NUMBER: **27DS16/2G03**

Voltage	Component	Conductors and Size	Cord Length (Feet)	Options
12=120V 20=208V 24=240V 27=277V 34=347V 48=480V	DS=Drop SO Cord	16/2G=2 Conductors Plus Ground 16/4G=4 Conductors Plus Ground	03=3' 06=6' 11=11' 15=15' 21=21'	2N=2 Neutral ⁽¹⁾ Notes (1) 16/4G only.

Order Information (0-10V)

SAMPLE ORDER NUMBER: **27DS16/2G03-010V**

Voltage	Component	Conductors and Size	Cable Length (Feet)	Dimming
12=120V 27=277V 34=347V	DS=Drop SO Cord	16/2G=2 Conductors Plus Ground	03=3' 06=6' 11=11' 15=15' 21=21'	010V=0-10V Dimming

Shipping Data

Cord Lengths	Unit Wt.	Standard Qty./Carton
3'	1.1 lbs.	N/A
6'	1.7 lbs.	N/A
11'	3.5 lbs.	N/A
15'	4.5 lbs.	N/A
21'	6.3 lbs.	N/A

Industrial Fixture Interface

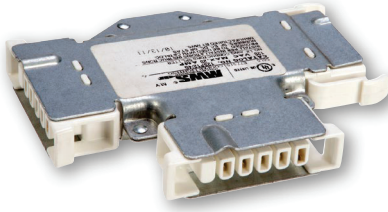

Circuit T CT

The MWS Circuit T (CT) feeds power to Industrial HID and Fluorescent lighting fixtures wired with Drop SO Cords (DS) or Drop Cables (DC).

MWS Circuit T provides circuit selection at each fixture plus allows fixtures to be disconnected without interrupting power downstream.

Flex cable with integral 0-10V dimming cable



System View - MWS Circuit T

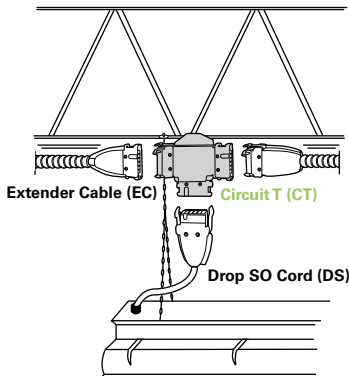

120V / 277V / 347V

12/4G - 10/4G

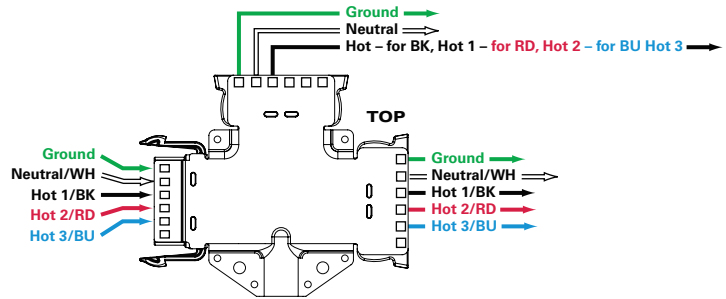

120V / 277V / 347V - 2 CIRCUIT, 2 NEUTRAL

12/4G 2N - 10/4G 2N

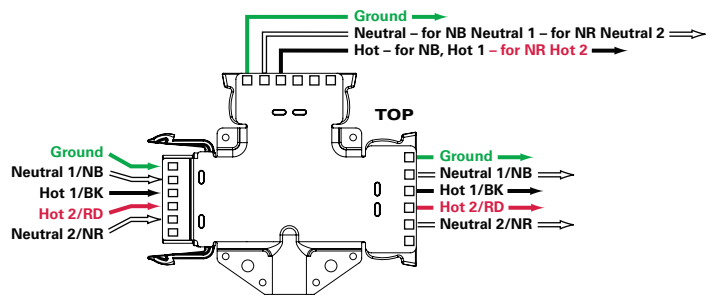

208V / 240V / 480V

12/4G - 10/4G

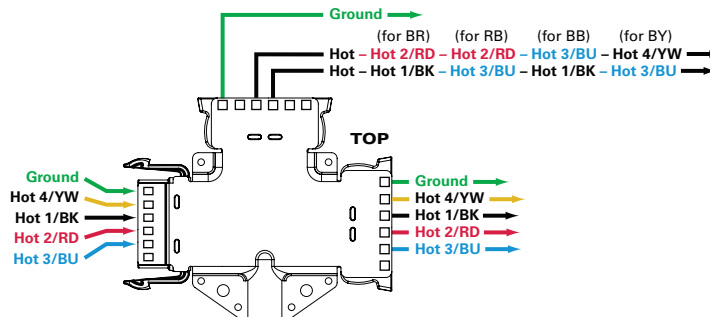

Order Information

SAMPLE ORDER NUMBER: **27CT12/4GBK**

Voltage	Component	Conductors and Size	Wiring	Options
12=120V 20=208V 24=240V 27=277V 34=347V 48=480V	CT=Circuit T	10/4G=10 gauge, 5 wires through Black/White/Red/Blue/Green 12/4G=12 gauge, 5 wires through Black/White/Red/Blue/Green	120V/ 277V/ 347V BK=3 Circuits through + Ground + Neutral Black/White/Green Down BU=3 Circuits through + Ground + Neutral Blue/White/Green Down RD=3 Circuits through + Ground + Neutral Red/White/Green Down 208V/ 240V/ 480V BB=4 Hots + Ground through Black/Blue/Green Down BR=4 Hots + Ground through Black/Red/Green Down BY=4 Hots + Ground through Blue/Yellow/Green Down NB=5 wires through with Black, Ground and Neutral for the Black Wires Down NR=5 wires through with Red, Ground and Neutral for the Red Wires Down RB=4 Hots + Ground through Red/Blue/Green Down	2N=2 Neutral

Order Information (0-10V)

SAMPLE ORDER NUMBER: **27CT12/2G-010V**

Voltage	Component	Conductors and Size	Dimming
12=120V 27=277V 34=347V	CT=Circuit T	12/2G=#12, 2 Conductors Plus Ground 10/2G=#10, 2 Conductors Plus Ground	010V=0-10V Dimming

Shipping Data

Unit Wt.	Standard Qty./ Carton
1.0 lbs.	24

Industrial Fixture Interface

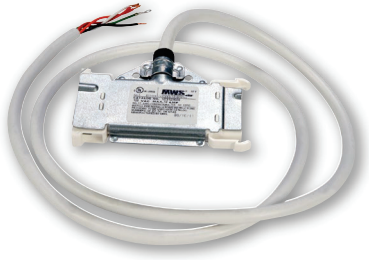

120V / 277V / 347V

12/2G - 12/3G - 12/4G - 10/2G - 10/3G - 10/4G

T SO Cord TS

The MWST SO Cord (TS) are used to feed Industrial HID and Fluorescent lighting fixtures while allowing the circuit to feed through to the next fixture.

- 16 AWG SO Cord is pre-stripped for easy termination at the fixture.

All unused outlets require a MWS dust cover. MWS ST, SP, SD, CT and TC are shipped with one dust attached

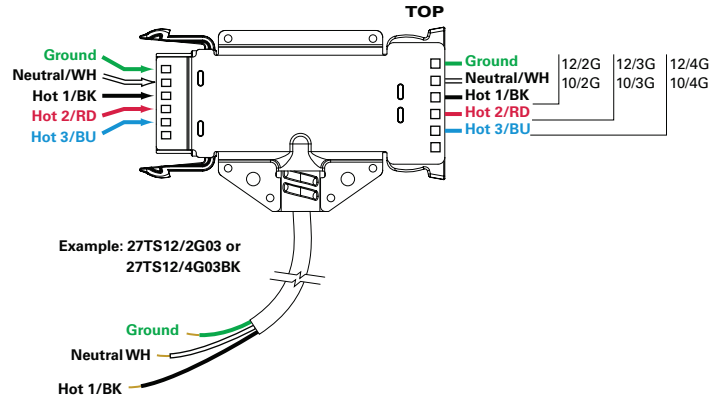

27TS12/4G03RD

12/4G - 10/4G

27TS12/4G03BU

12/4G - 10/4G

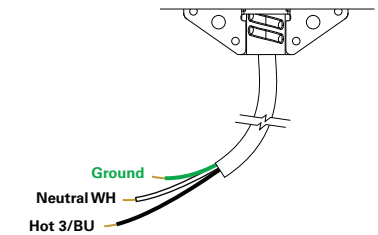
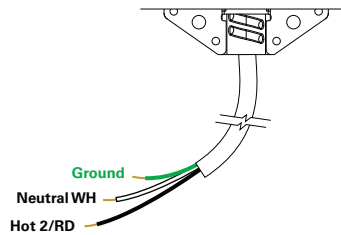

System View - MWS Switch Drop

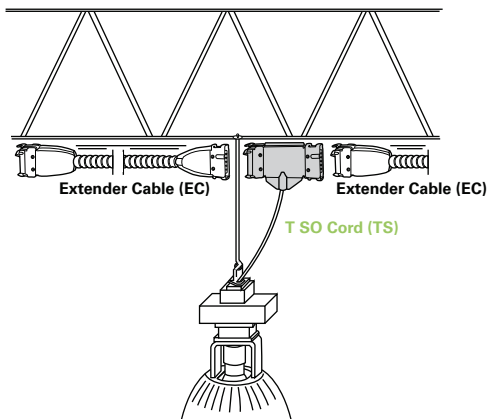

FOR 12/3G

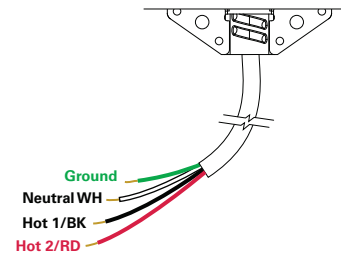

FOR 12/4G

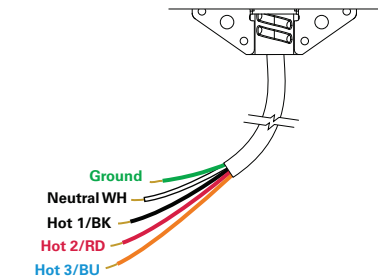

Order Information

SAMPLE ORDER NUMBER: **12TS10/4G03BK**

Voltage	Component	Conductors and Size	Cord Length (Feet)	Wiring	Options
12=120V 20=208V 24=240V 27=277V 34=347V 48=480V	TS=T SO Cord	10/2G=#10, 2 Conductors Plus Ground 10/3G=#10, 3 Conductors Plus Ground 10/4G=#10, 4 Conductors Plus Ground 12/2G=#12, 2 Conductors Plus Ground 12/3G=#12, 3 Conductors Plus Ground 12/4G=#12, 4 Conductors Plus Ground	03=3' 06=6' 11=11'	120V/ 277V/ 347V BK=Black, Hot 1, Neutral Ground to Fixtures BU=Blue, Hot 3, Neutral Ground to Fixtures NB=Black, Hot 1, Neutral 1 Ground to Fixtures NR=Red, Hot 2, Neutral 2 Ground to Fixtures RD=Red, Hot 2, Neutral 1 Ground to Fixtures	208V/ 240V/ 480V BB=Black, Blue, Hot 1, Hot 3 Ground to Fixtures BR=Black, Red, Hot 1, Hot 2 Ground to Fixtures BY=Blue, Yellow, Hot 3, Hot 4 Ground to Fixtures RB=Red, Blue, Hot 2, Hot 3 Ground to Fixtures
					2N=2 Circuit, 2 Neutral ⁽¹⁾ Notes (1) 12/4G and 10/4G only.

Order Information (0-10V)

SAMPLE ORDER NUMBER: **12TS10/4G03BK-010V**

Voltage	Component	Conductors and Size	Cable Length (Feet)	Dimming
12=120V 27=277V 34=347V	TS=T SO Cord	10/2G=#10, 2 Conductors 12/2G=#12, 2 Conductors	03=3' 06=6' 11=11'	010V=0-10V Dimming

Shipping Data

Cord Lengths	Unit Wt.	Standard Qty./ Carton
3'	1.1 lbs.	N/A
6'	1.7 lbs.	N/A
11'	2.7 lbs.	N/A

Industrial Fixture Interface

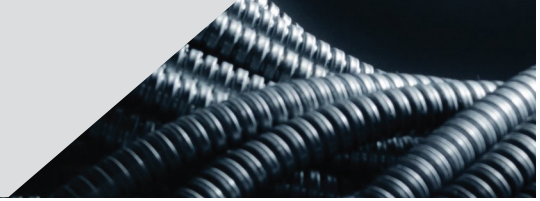

120V / 277V / 347V - 2 CIRCUIT, 2 NEUTRAL 12/4G / 10/4G

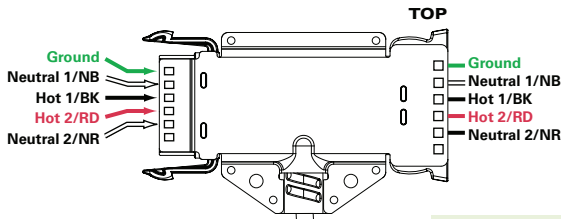

Example: 27TS12/4G03NB

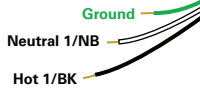

27TS12/4G03NR

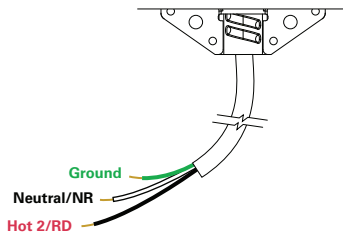

27TS12/4G03 2N

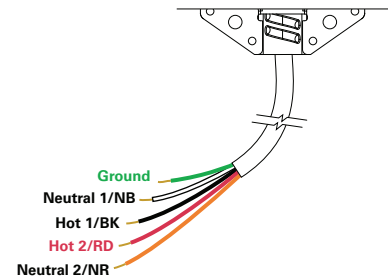

208V / 240V / 480V

12/2G - 12/3G - 12/4G - 10/2G - 10/3G - 10/4G

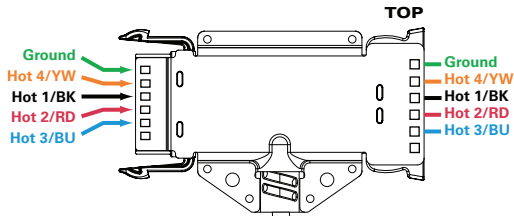

Example: 48TS12/2G03 or 48TS12/4G03BR



48TS12/3G03

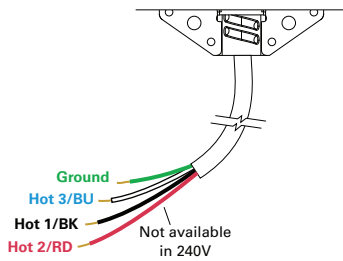

48TS12/4G03RB

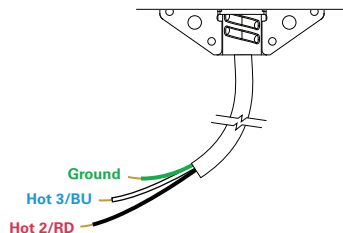

48TS12/4G03

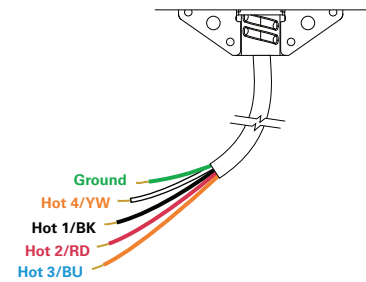

48TS12/4G03BB

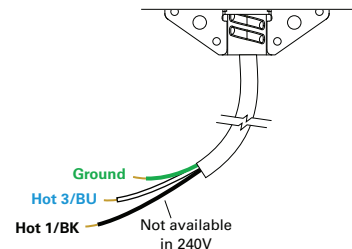

MWS in a Classroom Environment

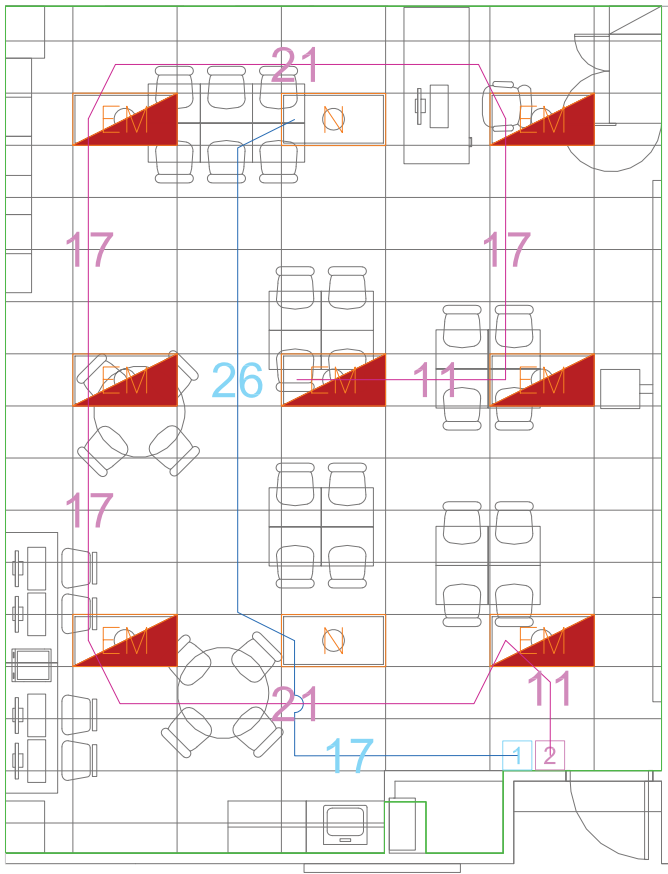

How to interpret the catalog numbers in BOM

If the fixture Drop Cable is to be factory installed, make sure to add the letters MW at the beginning of the fixture cable catalog number. If not, leave it blank. The Fixture Cable can be installed on typically any fixture that has a 1/2" knockout located on the fixture back or side. Using an HBLED fixture with an Fixture Fitting as an example, the fixture nomenclature should look like the following: HBLED-LD5-18SE-W-UNV-L850-ED2-U-MW12FF12/2G(MWS02).

For systems that require two circuits with dedicated neutrals, the 2N option is available with ground on 12/4 and 10/4 applications. Just enter 2N at the end of all 12/4 and 10/4 catalog component numbers.

12 = Voltage Used	ST = Component Used	12/2G = Wire Gauge Used / # of Wires in Cable with Ground
12 – 120 VAC	CT – Circuit T Fitting	12/2G – (1) 12-Gauge Circuit with Neutral and Ground
20 – 208 VAC	DC – Drop Cable	12/3G – (2) 12-Gauge Circuits with Shared Neutral and Ground
24 – 240 VAC	DS – D SO Cord Cable	12/4G – (3) 12-Gauge Circuits with Shared Neutral and Ground
27 – 277 VAC	FC – Fixture Cable	12/4G2N – (2) 12-Gauge Circuits with Dedicated Neutrals and Ground
34 – 347 VAC	FF – Fixture Fitting	10/2G – (1) 10-Gauge Circuit with Neutral and Ground
48 – 480 VAC	PF – Power Fitting	10/3G – (2) 10-Gauge Circuits with Shared Neutral and Ground
	SD – Switch Drop Cable	10/4G – (3) 10-Gauge Circuits with Shared Neutral and Ground
	SF – Starter Fixture Cable	10/4G2N – (2) 10-Gauge Circuits with Dedicated Neutrals and Ground
	SP – Splitter Fitting	
	ST – Starter Fitting	
	TC – Tee Cable	
	TS – Tee SO Cord Cable	

Sequence of Operations

- Normal lights are powered from normal source power
- EM lights are powered from generator/inverter power source
- Both normal and emergency lights are being fed by 120 VAC
- FF – A 12/2 fixture fitting system is used for this installation
- Fixture counts are also represented by fixture fitting counts

Bill of Materials

Label	Symbol	Qty	Catalog #	Description
1		1	12ST12/2G	Starter Fitting / Starter Cable
2		1	12ST12/2G	Starter Fitting / Starter Cable
11		2	12EC12/2G11	11' Extender Cable
17		4	12EC12/2G17	17' Extender Cable
21		2	12EC12/2G21	21' Extender Cable
26		1	12EC12/2G26	26' Extender Cable
EM		7	12FF12/2G (M02)	Fixture Fitting
N		2	12FF12/2G (M02)	Fixture Fitting

MWS (M02) Wiring Instruction

- HOT 1 wired to Driver or Sensor HOT
- Neutral wired to Driver or Sensor Neutral
- Green wire to Fixture Ground
- Cap off unused wires

Starter Fitting ST



Extender Cable EC



Fixture Fitting FF



Fixture Fitting System

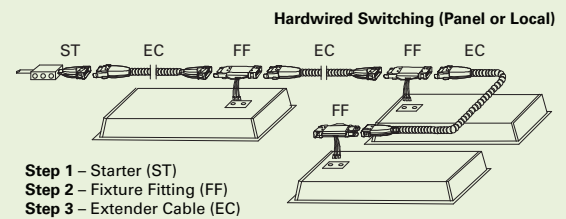

FPanel LED Panel

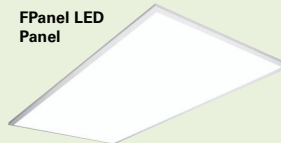

Note: These drawings have been scaled down to fit in the window and are not actually set to it proper scale.

0-10 Volt Office Wiring Environment

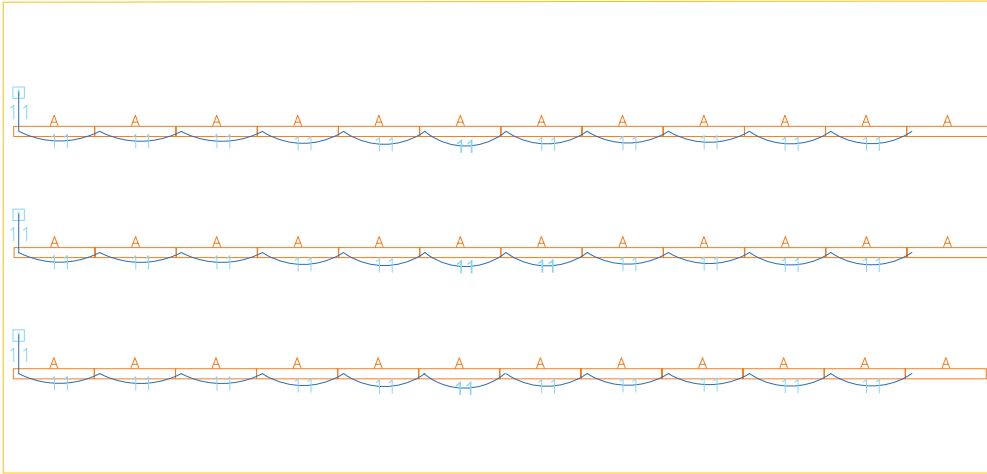
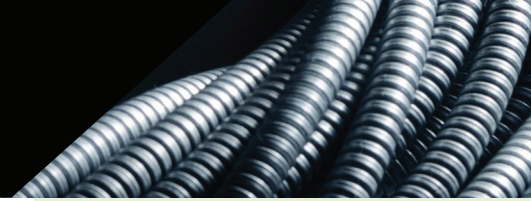

Lighting

- Normal lights are powered from normal source power
- These fixtures require both power and 0-10V dimming control within the same MWS cable
- The 0-10V system is only designed for single circuit systems with 0-10V control wires included in the same cable
- Fixture counts are also represented by fixture fitting counts

How to interpret the catalog numbers in BOM

If the fixture Drop Cable is to be factory installed, make sure to add the letters MW at the beginning of the fixture cable catalog number. If not, leave it blank. The Fixture Cable can be installed on typically any fixture that has a 1/2" knockout located on the fixture back or side. Using an HBLED fixture with an Fixture Fitting as an example, the fixture nomenclature should look like the following: HBLED-LD5-18SE-W-UNV-L850-ED2-U-MW12FF12/2G(MWS02).

For systems that require two circuits with dedicated neutrals, the 2N option is available with ground on 12/4 and 10/4 applications. Just enter 2N at the end of all 12/4 and 10/4 catalog component numbers.

12 = Voltage Used	ST = Component Used	12/2G = Wire Gauge Used / # of Wires in Cable with Ground
12 – 120 VAC	CT – Circuit T Fitting	12/2G – (1) 12-Gauge Circuit with Neutral and Ground
20 – 208 VAC	DC – Drop Cable	12/3G – (2) 12-Gauge Circuits with Shared Neutral and Ground
24 – 240 VAC	DS – D S0 Cord Cable	12/4G – (3) 12-Gauge Circuits with Shared Neutral and Ground
27 – 277 VAC	FC – Fixture Cable	12/4G2N – (2) 12-Gauge Circuits with Dedicated Neutrals and Ground
34 – 347 VAC	FF – Fixture Fitting	10/2G – (1) 10-Gauge Circuit with Neutral and Ground
48 – 480 VAC	PF – Power Fitting	10/3G – (2) 10-Gauge Circuits with Shared Neutral and Ground
	SD – Switch Drop Cable	10/4G – (3) 10-Gauge Circuits with Shared Neutral and Ground
	SF – Starter Fixture Cable	10/4G2N – (2) 10-Gauge Circuits with Dedicated Neutrals and Ground
	SP – Splitter Fitting	
	ST – Starter Fitting	
	TC – Tee Cable	
	TS – Tee S0 Cord Cable	

Bill of Materials

Label	Symbol	Qty	Catalog #	Description
		3	27ST12/2G-010V	Starter Fitting / Starter Cable
11		39	27EC12/2G11-010V	11' Extender Cable with 0-10V Control Wires
A		36	27FF12/2G-010V (M01)	Fixture Fitting with 0-10V Control Wires

MWS (M02) Wiring Instruction

- M01
- HOT 1 wired to Driver HOT
 - Neutral wired to Driver Neutral
 - Green wire to Fixture Ground
 - Purple wire to Driver Purple wire
 - Grey wire to Driver Grey wire

Starter Fitting ST



Extender Cable EC



Fixture Fitting FF

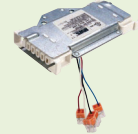

Fixture Fitting System



- Step 1 – Starter (ST)
Step 2 – Fixture Fitting (FF)
Step 3 – Extender Cable (EC)



WSL Linear

Note: These drawings have been scaled down to fit in the window and are not actually set to it proper scale.

MWS in a Manufacturing Environment

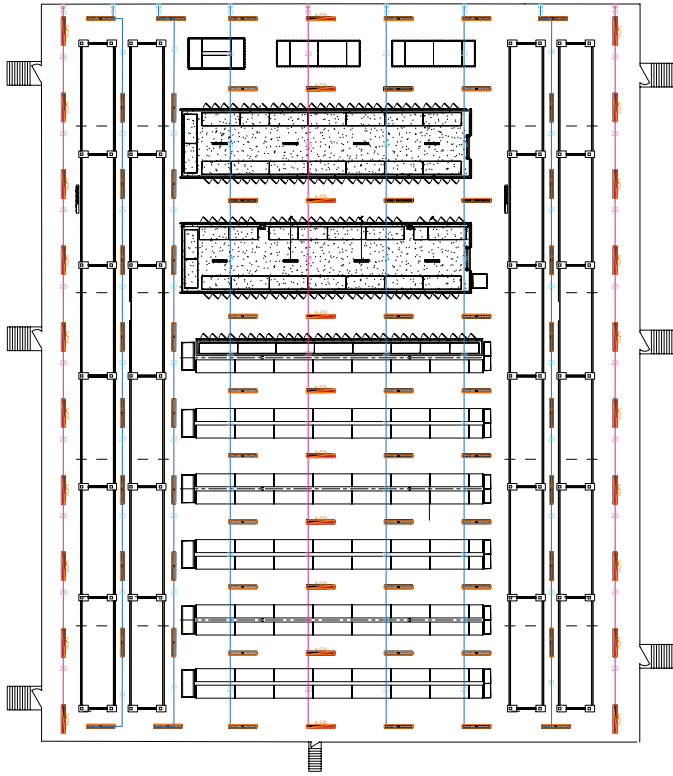

How to interpret the catalog numbers in BOM

If the fixture Drop Cable is to be factory installed, make sure to add the letters MW at the beginning of the fixture cable catalog number. If not, leave it blank. The Fixture Cable can be installed on typically any fixture that has a 1/2" knockout located on the fixture back or side. Using an HBLED fixture with an Fixture Fitting as an example, the fixture nomenclature should look like the following: HBLED-LD5-18SE-W-UNV-L850-ED2-U-MW12FF12/2G(MWS02).

For systems that require two circuits with dedicated neutrals, the 2N option is available with ground on 12/4 and 10/4 applications. Just enter 2N at the end of all 12/4 and 10/4 catalog component numbers.

12 = Voltage Used	ST = Component Used	12/2G = Wire Gauge Used / # of Wires in Cable with Ground
12 – 120 VAC	CT – Circuit T Fitting	12/2G – (1) 12-Gauge Circuit with Neutral and Ground
20 – 208 VAC	DC – Drop Cable	12/3G – (2) 12-Gauge Circuits with Shared Neutral and Ground
24 – 240 VAC	DS – D SO Cord Cable	12/4G – (3) 12-Gauge Circuits with Shared Neutral and Ground
27 – 277 VAC	FC – Fixture Cable	12/4G2N – (2) 12-Gauge Circuits with Dedicated Neutrals and Ground
34 – 347 VAC	FF – Fixture Fitting	10/2G – (1) 10-Gauge Circuit with Neutral and Ground
48 – 480 VAC	PF – Power Fitting	10/3G – (2) 10-Gauge Circuits with Shared Neutral and Ground
	SD – Switch Drop Cable	10/4G – (3) 10-Gauge Circuits with Shared Neutral and Ground
	SF – Starter Fixture Cable	10/4G2N – (2) 10-Gauge Circuits with Dedicated Neutrals and Ground
	SP – Splitter Fitting	
	ST – Starter Fitting	
	TC – Tee Cable	
	TS – Tee SO Cord Cable	

Sequence of Operations

- Both normal and emergency lights are powered from the same 208 VAC normal source power
- EM lights contains a battery backup for emergency purposes. This will require an additional constant Hot wire for power.
- This location requires a 12/4TS System with (2) alternating circuits and a constant HOT wire to power up the battery
- Fixture counts are also represented by T SO Cord cable drop counts

Bill of Materials

Label	Symbol	Qty	Catalog #	Description
		1	20ST12/2G	Starter Fitting / Starter Cable
11		1	20EC12/2G11	11' Extender Cable
21		2	20EC12/2G21	21' Extender Cable
26		4	20EC12/2G26	26' Extender Cable
31		2	20EC12/2G31	31' Extender Cable
36		1	20EC12/2G36	36' Extender Cable
A		7	20TS12/2G06(M05)	T SO Cord
A-EM		2	20TS12/GG06(M05)	T SO Cord

MWS (M02) Wiring Instruction

- M05 • 2 Circuit Dual Driver
- HOT 1 wired to Inboard Driver HOT
 - HOT 2 wired to Outboard Driver HOT
 - Neutral wired to both Driver Neutrals
 - Green wire to Fixture Ground
 - Cap off unused Grounds



T SO Cord System

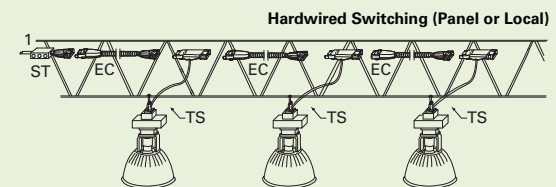

- Step 1 – Starter (ST)
 Step 3 – T SO Cord (TS)
 Step 4 – Extender Cable (EC)



Note: These drawings have been scaled down to fit in the window and are not actually set to it proper scale.

MWS in a Healthcare Environment

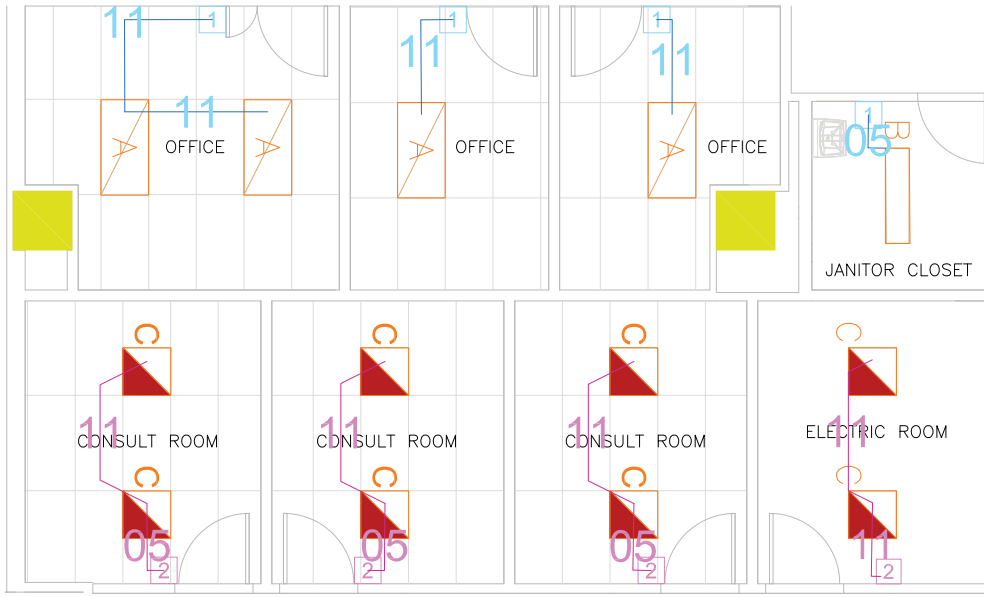

Lighting

- Both normal and emergency lights are powered from the same 277 VAC normal source power
- EM lights contains a battery backup for emergency purposes. This will require an additional constant Hot wire for power.
- There are (2) different systems being used in this application. FF for office and consult locations and TC for open ceiling locations.
- All these locations are using 12-gauge 2-wire or 3-wire systems, because the different areas require and permit it
- Office locations are using sensor controlled fixtures for ON and OFF control, while the others are just switch controlled
- Fixture counts are also represented by fixture fittings and T Cable counts

Fixture Fitting System

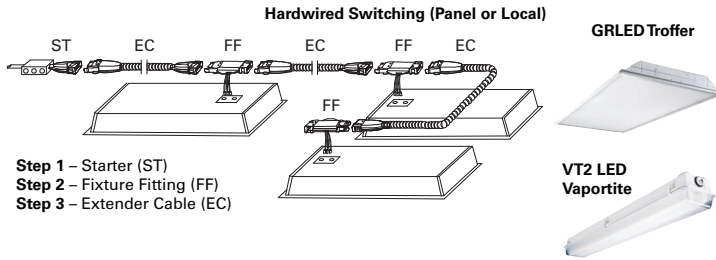

- Step 1 – Starter (ST)
- Step 2 – Fixture Fitting (FF)
- Step 3 – Extender Cable (EC)

How to interpret the catalog numbers in BOM

If the fixture Drop Cable is to be factory installed, make sure to add the letters MW at the beginning of the fixture cable catalog number. If not, leave it blank. The Fixture Cable can be installed on typically any fixture that has a 1/2" knockout located on the fixture back or side. Using an HBLED fixture with an Fixture Fitting as an example, the fixture nomenclature should look like the following: HBLED-LD5-18SE-W-UNV-L850-ED2-U-MW12FF12/2G(MWS02).

For systems that require two circuits with dedicated neutrals, the 2N option is available with ground on 12/4 and 10/4 applications. Just enter 2N at the end of all 12/4 and 10/4 catalog component numbers.

12 = Voltage Used	ST = Component Used	12/2G = Wire Gauge Used / # of Wires in Cable with Ground
12 – 120 VAC	CT – Circuit T Fitting	12/2G – (1) 12-Gauge Circuit with Neutral and Ground
20 – 208 VAC	DC – Drop Cable	12/3G – (2) 12-Gauge Circuits with Shared Neutral and Ground
24 – 240 VAC	DS – D S0 Cord Cable	12/4G – (3) 12-Gauge Circuits with Shared Neutral and Ground
27 – 277 VAC	FC – Fixture Cable	12/4G2N – (2) 12-Gauge Circuits with Dedicated Neutrals and Ground
34 – 347 VAC	FF – Fixture Fitting	10/2G – (1) 10-Gauge Circuit with Neutral and Ground
48 – 480 VAC	PF – Power Fitting	10/3G – (2) 10-Gauge Circuits with Shared Neutral and Ground
	SD – Switch Drop Cable	10/4G – (3) 10-Gauge Circuits with Shared Neutral and Ground
	SF – Starter Fixture Cable	10/4G2N – (2) 10-Gauge Circuits with Dedicated Neutrals and Ground
	SP – Splitter Fitting	
	ST – Starter Fitting	
	TC – Tee Cable	
	TS – Tee S0 Cord Cable	

Bill of Materials

Label	Symbol	Qty	Catalog #	Description
	1	4	27ST12/2G	Starter Fitting / Starter Cable
	2	4	27ST12/3G	Starter Fitting / Starter Cable
05		1	27EC12/2G05	05' Extender Cable
05		3	27EC12/3G05	05' Extender Cable
11		4	27EC12/2G11	11' Extender Cable
1		5	27EC12/3G11	11' Extender Cable
A		4	27FF12/2G(M02)	Fixture Fitting
C		6	27FF12/3G(M10)	Fixture Fitting
B		4	27TC12/2G05 (M02)	T Cable
C		6	27TC12/3G05 (M10)	T Cable

MWS (M02) Wiring Instruction

- M02
- HOT 1 wired to Driver or Sensor HOT
 - Neutral wired to Driver or Sensor Neutral
 - Green wire to Fixture Ground
 - Cap off unused wires

- M10
- HOT 1 to Driver HOT
 - HOT 2 to Battery HOT
 - Neutral wired to Battery and Driver Neutral
 - Green wire to Fixture Ground

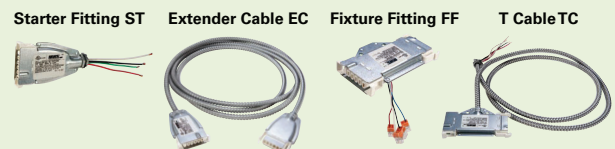

Note: These drawings have been scaled down to fit in the window and are not actually set to it proper scale.

MWS in a Warehouse Environment

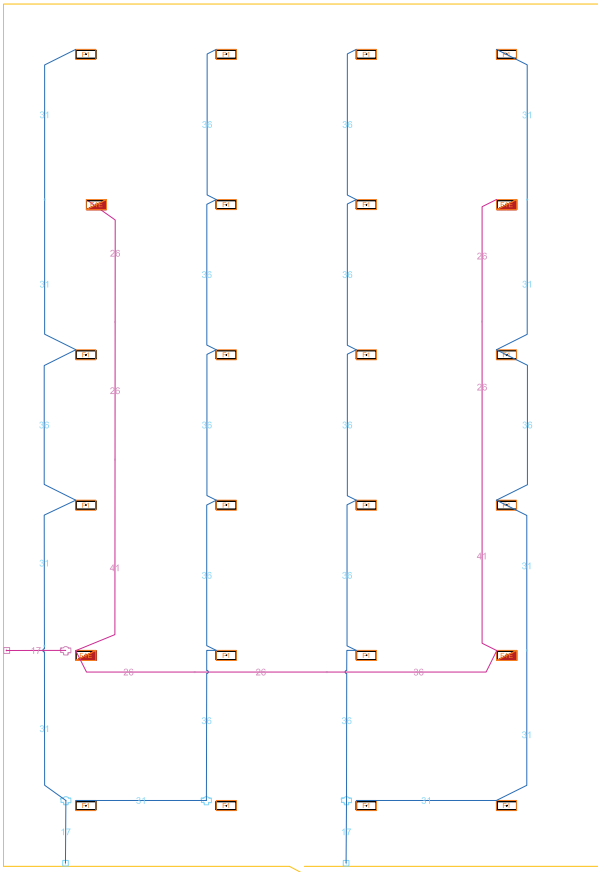

How to interpret the catalog numbers in BOM

If the fixture Drop Cable is to be factory installed, make sure to add the letters MW at the beginning of the fixture cable catalog number. If not, leave it blank. The Fixture Cable can be installed on typically any fixture that has a 1/2" knockout located on the fixture back or side. Using an HBLED fixture with an Fixture Fitting as an example, the fixture nomenclature should look like the following: HBLED-LD5-18SE-W-UNV-L850-ED2-U-MW12FF12/2G(MWS02).

For systems that require two circuits with dedicated neutrals, the 2N option is available with ground on 12/4 and 10/4 applications. Just enter 2N at the end of all 12/4 and 10/ catalog component numbers.

12 = Voltage Used	ST = Component Used	12/2G = Wire Gauge Used / # of Wires in Cable with Ground
12 – 120 VAC	CT – Circuit T Fitting	12/2G – (1) 12-Gauge Circuit with Neutral and Ground
20 – 208 VAC	DC – Drop Cable	12/3G – (2) 12-Gauge Circuits with Shared Neutral and Ground
24 – 240 VAC	DS – D SO Cord Cable	12/4G – (3) 12-Gauge Circuits with Shared Neutral and Ground
27 – 277 VAC	FC – Fixture Cable	12/4G2N – (2) 12-Gauge Circuits with Dedicated Neutrals and Ground
34 – 347 VAC	FF – Fixture Fitting	10/2G – (1) 10-Gauge Circuit with Neutral and Ground
48 – 480 VAC	PF – Power Fitting	10/3G – (2) 10-Gauge Circuits with Shared Neutral and Ground
	SD – Switch Drop Cable	10/4G – (3) 10-Gauge Circuits with Shared Neutral and Ground
	SF – Starter Fixture Cable	10/4G2N – (2) 10-Gauge Circuits with Dedicated Neutrals and Ground
	SP – Splitter Fitting	
	ST – Starter Fitting	
	TC – Tee Cable	
	TS – Tee SO Cord Cable	

Sequence of Operations

- Normal power source is feeding all normal light fixtures in both normal lighting circuits shown in drawing
- EM lights are powered from Generator/Inverter power source and is feeding all EM fixtures connected to the same EM circuit shown in drawing
- Both normal and emergency lights are requiring 480 VAC power source to power up all the warehouse fixtures
- DS – a 10/2 Cable System with 16/2 DS SO Cord Drop Cable is used in this installation to compensate for distance and load requirements
- DS Cord connects to a CT Fitting for easy isolation of fixture from power
- CT Fittings are used for isolation of power or as a Splitter for redirection of power
- Fixture counts are also represented by Drop SO Cord cable counts

Bill of Materials

Label	Symbol	Qty	Catalog #	Description
Connection Point		10		Two or more Extender Cables connected together
		3	48ST10/2G	Starter Fitting/Starter Cable
17		3	48EC10/2G17	17' Extender Cable
26		6	48EC10/2G26	26' Extender Cable
31		10	48EC10/2G31	31' Extender Cable
36		13	48EC10/2G36	36' Extender Cable
41		2	48EC10/2G41	41' Extender Cable
		28	48CT10/4G	Circuit T Fitting
F1		20	48DS16/2G06(M12)	Drop SO Cord Cable
F1E		4	48DS16/2G06(M12)	Drop SO Cord Cable

MWS (M12) Wiring Instruction

- HOT 1 wired to Fixture HOT 1
- HOT 2 wired to Fixture HOT 2
- Green wire to Fixture Ground

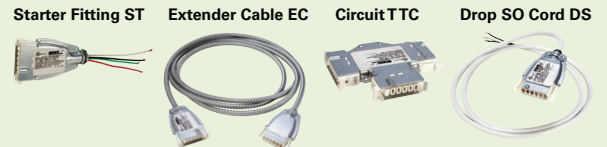

Drop SO Cord System

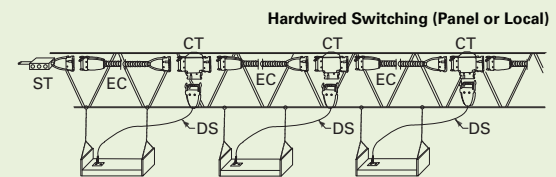

- Step 1** – Starter (ST)
- Step 2** – Circuit T (CT)
- Step 3** – Drop SO Cord (DS)
- Step 4** – Extender Cable (EC)



Note: These drawings have been scaled down to fit in the window and are not actually set to it proper scale.

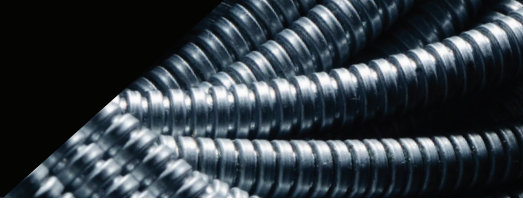

Lined area for notes with horizontal ruling lines.

Lighting Product Lines

Ametrix
AtLite
Corelite
Ephesus
Fail-Safe
Halo
Halo Commercial
Invue
io
Iris
Lumark
Lumière
McGraw-Edison
Metalux
MWS
Neo-Ray
Portfolio
RSA
Shaper
Streetworks
Sure-Lites

Controls Product Lines

Fifth Light Technology
Greengate
iLight (International Only)
iLumin
Zero 88

Connected Lighting Systems

Distributed Low-Voltage Power
HALO Home
iLumin Plus
Enlighted
WaveLinx
Trellix

Cooper Lighting Solutions

1121 Highway 74 South
Peachtree City, GA 30269
P: 770-486-4800
www.cooperlighting.com
For service or technical assistance:
1-800-553-3879

Canada Sales
5925 McLaughlin Road
Mississauga, Ontario L5R 1B8
P: 905-501-3000
F: 905-501-3172

© 2020 Cooper Lighting Solutions
All Rights Reserved
Printed in USA
Publication No. BR503056EN
November 6, 2020 8:51 AM

Cooper Lighting Solutions is a registered trademark.

All other trademarks are property of their respective owners.

Product availability, specifications, and compliances are subject to change without notice.

