

Project		Catalog #		Type	
Prepared by		Notes		Date	

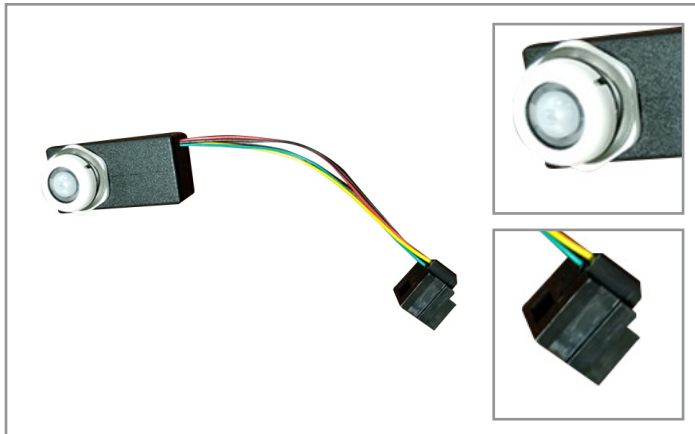

# WaveLinx Wireless

## Ambient Integrated Sensor

Motion and Closed Loop Daylighting, IoT-ready

### Typical Applications

Office • Education • Healthcare • Retail

### Interactive Menu

- Order Information page 2
- Additional Resources page 3
- Connected Systems page 5
- Product Warranty

### Product Certification

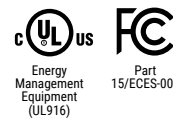

- Meets latest ASHRAE Standard 90.1 requirements
- Meets latest IECC requirements
- Meets latest CEC Title 24 requirements

### Product Features



### Top Product Features

- Easily enables 0-10V luminaires to become WaveLinx enabled
- Passive InfraRed (PIR) motion sensor with coverage up to 500 sq-ft
- Integrated photocell for closed loop daylight harvesting
- Software configurable settings with WaveLinx application
- Luminaire junction box or driver compartment connections
- Provides wireless bi-directional communications with WaveLinx system
- Multi-colored LEDs for sensor status and diagnostics

### Dimensional Details

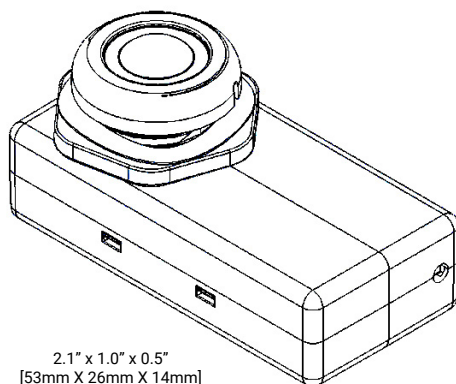

2.1" x 1.0" x 0.5"  
[53mm X 26mm X 14mm]

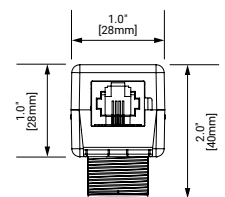
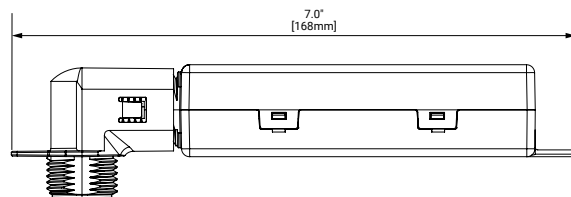
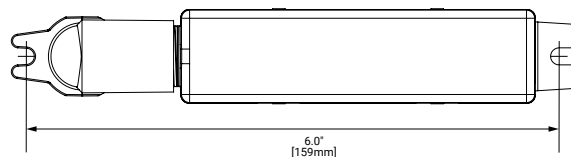

additional product diagrams

## Order Information

WaveLinx Ambient Integrated Sensors enable ambient luminaire to be a part of the WaveLinx Connected Lighting (WCL) system and requires a Wireless Area Controller (WAC) for full functionality.

WaveLinx Ambient Integrated Sensors are used to provide occupancy and daylight dimming to spaces from the ambient light fixture. For energy code compliance, additional sensors may not be required.

### Catalog Number

Catalog #	Description
OEM-WAA	WaveLinx Ambient Integrated Sensor, 8-15ft (2.4-4.6m)
<b>Notes</b>	<b>Notes</b>
For use with indoor ambient light fixtures.	When used as a component in the WaveLinx Connected Lighting system, WaveLinx system design best practices (including Wireless Area Controller placement, line of sight distances, number of hops, etc.) must be followed.

## Required Integration Components

### Catalog Number

### Catalog Number

Catalog Number	Description
OEM-MSP3IVMVDC1EP	WaveLinx Ambient Control Module
OEM-WLX-CABLE-054	OEM WaveLinx Integrated Sensor Cable 54"

## Product Specifications

### Key Features

The Integrated Sensor system is an integrated control system that provides occupancy and daylight dimming controls. Daylight dimming is implemented as a closed loop control. The system is a low-cost, out-of-the-box solution to lighting code compliance with the added benefit of personal control after commissioning.

- Occupancy detection
- Continuous daylight dimming
- 0-10 V dimming
- Occupancy sensitivity
- Fresnel lens | coverage

### Mechanical

#### Environment:

- **Operating temperature:** 32°F to 131°F (0°C to 55°C)
- **Storage temperature:** 14°F to 158°F (-10°C to 70°C)
- **Relative humidity operating:** 5% to 95% non-condensing
- For indoor use only

#### Mounting:

Mounting: Fixture Mount

Mounting Height: 8-15 ft (2.4m - 4.5m)

Color: Matte White facing customer with Black enclosure

Sensor Housing: UV stabilized plastic

### Electrical

#### Sensor Input Requirements:

- Range input voltage: 12-15 VDC
- Rated input current: 100mA Max
- Rated input frequency: DC

### Sensor Hardware Specifications

Processor: EFR32MG12P132F1024GM48

Peripheral Connectivity: UART (2-wire)

#### Status Indicators:

- Per WaveLinx - see manual
- LED blinks when motion is detected
- White blink means sensor is communicating with a Wireless Area Controller
- Green blink may mean one of two things:
  - Sensor is in "out-of-the-box" mode (never connected to a Wireless Area Controller)
  - Sensor is in "disconnected" mode (cannot find its Wireless Area Controller)

### Wireless Specifications

**Radio:** 2.4GHz

**Standard:** IEEE 802.15.4

**Transmitter Power:** + 10dBm

**Configuration type:** Router, End Point

**Range:** 75ft (25m) LOS

**# of Walls:** 2 interior walls standard construction

### System Performance

**Maximum number of Devices:** 150 per Wireless Area Controller (best practice 100 devices)

### Standards/Ratings

- cULus Listed - Energy Management Equipment (UL916)
- FCC Part 15/ECES-003
- Manufactured in an ISO 9001 certified factory
- Meets ASHRAE Standard 90.1 requirements
- Meets IECC 2018 requirements
- Meets CEC Title 24 requirements
- Meets latest ISED OR IC requirements

#### Product Safety:

- IEC 60950-1
- UL 60950-1
- EN 60950-1
- CAN/CSA-C22.2 No. 60950-1

#### Environmental Regulations:

- WEEE Directive 2012/19/EU

### Warranty

Five year warranty standard

## System Architecture

This diagram shows the main components of the WaveLinx Connected Lighting (WCL) system. The WCL system communicates using wireless mesh technology based on the 802.15.4 standard. A PoE LAN connection for each Wireless Area Controller (WAC) is required for power and data access to the building wireless network. System setup is achieved through a simple mobile application via wireless communication to the system.

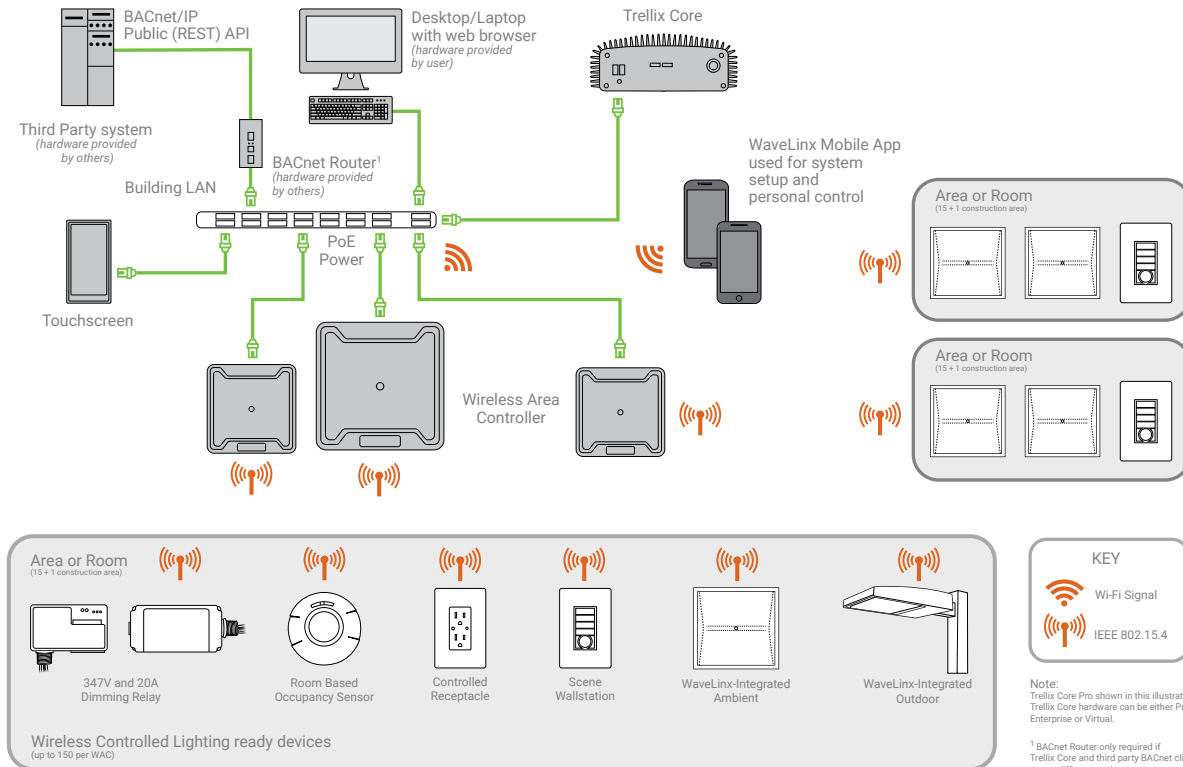

## Overview

The WaveLinx integrated sensor is an integral part of the WaveLinx Connected Lighting System and offers passive infrared (PIR) occupancy and a photocell for closed loop daylighting. WaveLinx ambient integrated sensors offer installation heights 8 to 15 feet and have coverage patterns up to 500 square feet. When part of WaveLinx, the sensor operates on a wireless mesh network based on IEEE 802.15.4 standards.

WaveLinx integrated sensors receive power from their co-located light fixture with no batteries to replace. The sensor in combination with the WaveLinx Mobile application allows you to gain considerable energy savings from occupancy and daylight sensing lighting control. The WaveLinx Mobile application allows you to map the sensor to any area or control zone, select occupancy or vacancy, occupied and unoccupied light levels and set the hold time.

For wiring / installation details:



## Field of View

### TOP VIEW:

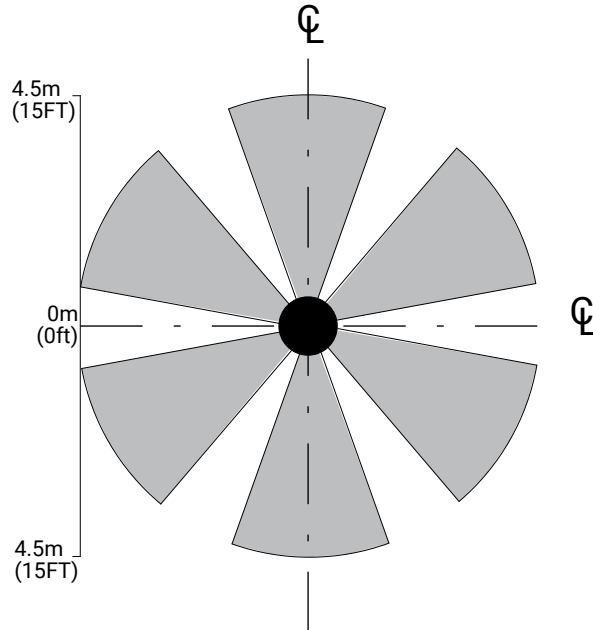

Note: The "beam" pattern obtained depends strongly on the detector used with this array. The pattern shown is intended solely as a general guide and is not to scale.

### SIDE VIEW:

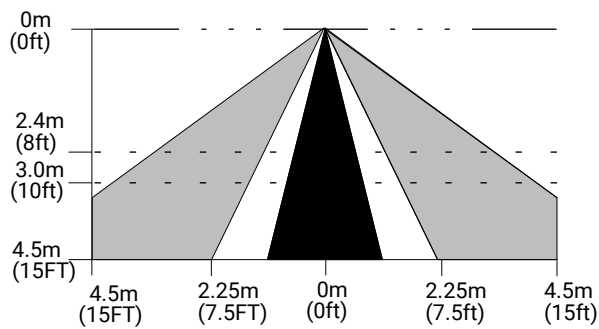

## Mounting Height

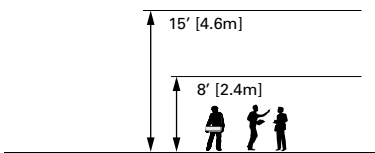

## Connected Systems

- Trellix

### Better Data. Better Decisions.

Trellix combined with our WaveLinX Connected Lighting System is a distributed network of LED lighting fixtures with integrated sensing and beacon technology that captures real-time data; making your facility smarter so you can make smarter decisions.

Trellix provides an open IoT platform and infrastructure that connects intelligent sensors leveraging the real-estate of the physical light fixture to solve higher complexity problems in a commercial building to deliver actionable insights through the aggregation of valuable data.

